



TECNOLOGIE FRB

FRB



CATALOGO GENERALE
GENERAL CATALOGUE

2021



Contropunte rotanti e fisse
Live centers and dead centers



SCOPRI LA NOSTRA GAMMA COMPLETA DI CONTROPUNTE
DISCOVER OUR COMPLETE RANGE OF LIVE CENTERS



FRB

TECNOLOGIE

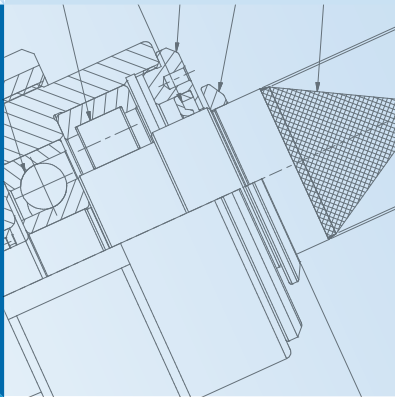

LEGENDA ICONE / ICONS KEY

DESTINAZIONE D'USO INTENDED USE



TORNITURA
TURNING



RETTIFICA
GRINDING



DENTATURA
GEAR CUTTING

CARATTERISTICHE TECNICHE TECHNICAL FEATURES

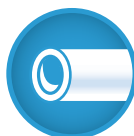

Lavorazione tubi
Pipes machining



Tornitura del temprato
Hard turning



Albero molleggiato
Sprung shaft



Rotante
Rotating

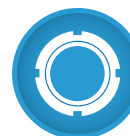

Ghiera estrazione
Extraction nut



Lavorazione con trascinatore
Machining with face driver



Alta velocità
High speed



Carichi differenziati
Differentiated loads



Carichi pesanti
Heavy loads



Cuscinetti
Bearings

Quantità
Quantity

PITTOGRAMMI PICTOGRAMS



Codice contropunta
Live center code



Codice contropunta con albero integrale
Live center with integral shaft code



Codice contropunta con albero integrale e punta di metallo duro
Live center with integral shaft and hard carbide tip insert code



Codice contropunta con albero integrale prolungato
Live center with extended integral shaft code



Codice contropunta con albero integrale prolungato e punta di metallo duro
Live center with extended integral shaft and hard carbide tip insert code



Cono morse
Morse taper



Attacco cilindrico
Cylindrical connection



Attacco VDI
VDI connection



Concentricità
Concentricity



Rotondità
Roundness



Lubrificazione con grasso
Grease lubrication



Lubrificazione con olio nebulizzato
Oil mist lubrication



Carico assiale max kg/Lb
Max axial load kg/Lb





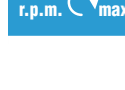



Carico radiale max. (peso pezzo) kg/Lb
Max radial load (workpiece weight) kg/Lb

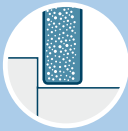

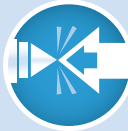

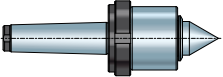
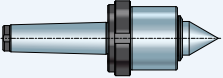
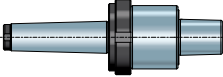
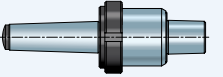
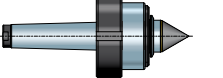
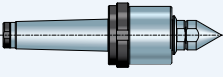
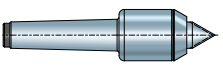
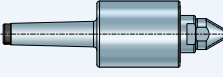
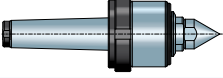
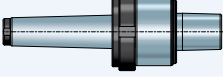
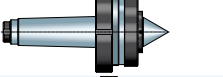
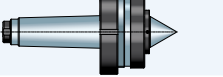
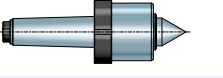
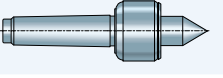

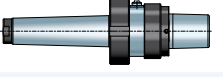
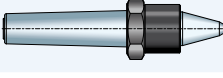
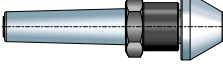



Velocità max giri/min'
Max speed r.p.m.



		DESTINAZIONE D'USO - INTENDED USE					
		Pagina / Page	 TORNITURA TURNING	 RETTIFICA GRINDING	 DENTATURA GEAR CUTTING	 Carichi differenziati Differentiated loads	 Lavorazione tubi Pipes machining
80		4	●			● ●	
85		6	●			● ●	
80-T		8	●			● ●	●
85-T		8	●			● ●	●
2008		10	●				
2006		11	●				
81		9	●				
81R		9	●				
2000		12	●				
2000-T		13	●				●
88		22	●	●			
88-T		22	●	●			●
86		23	●	●		● ●	
RAPIDO		23	●				
92		16		●			
92F		18		●			
92M		19		●			●
82		20			●		
82-T		21			●		●

● ● Contropunte a carichi differenziati, particolarmente indicate per lavorazione in abbinamento a trascinatori.
Live centers with axial load distribution, particularly suitable for machining with face drivers.

CARATTERISTICHE TECNICHE - TECHNICAL FEATURES

							
Tornitura del temprato <i>Hard turning</i>	Albero molleggiato <i>Sprung shaft</i>	Rotante <i>Rotating</i>	Ghiera estrazione <i>Extraction nut</i>	Lavorazione con trascinatore <i>Machining with face driver</i>	Alta velocità <i>High speed</i>	Carichi pesanti <i>Heavy loads</i>	Cuscinetti (Qt.) <i>Bearings (Qty.)</i>
		●	●	●			5
		●	●	●			5
		●	●	●			5
		●	●	●			5
●		●	●	●			5
		●	●		●		6
	●	●					3
	●	●					5
		●	●	●			4
		●	●	●			4
		●	●	●		●	5
		●	●	●		●	5
		●	●	●		●	6
		●					3
		●	●	●			5
		●	●	●			5
		●	●	●			5
		●	●	●			3
		●	●	●			3

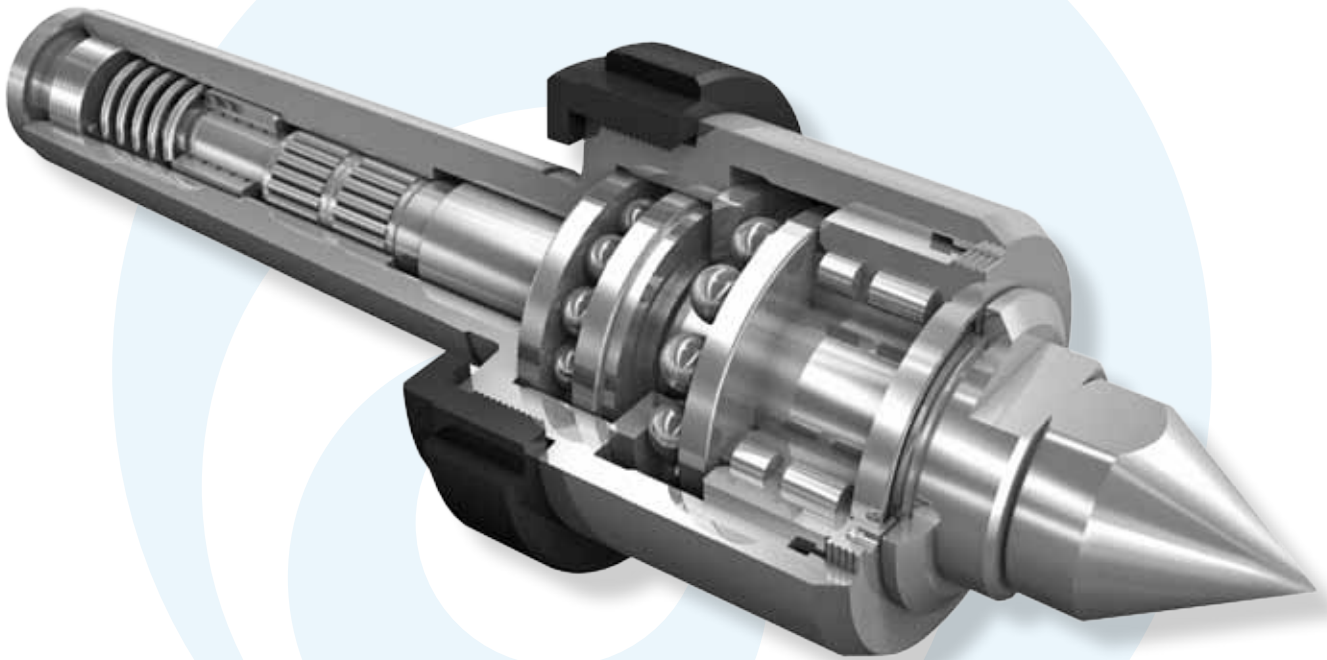

TECNOLOGIE FRB progetta, costruisce e commercializza diverse linee di prodotti brevettati, veramente innovativi e di concezione tecnologica avanzata nel settore delle lavorazioni meccaniche di tornitura, dentatura e rettifica.

Costantemente impegnata nella ricerca tecnologica e nel miglioramento delle prestazioni dei propri prodotti, dalla sua fondazione nei primi anni 60, **TECNOLOGIE FRB** ha riscosso la fiducia di numerose aziende di primaria importanza nazionale e internazionale, che utilizzano abitualmente i suoi prodotti. Inoltre collabora attivamente con gli uffici tecnici dei più importanti costruttori di macchine utensili italiani ed esteri. Gli appuntamenti con le novità tecnologiche (sempre più frequenti) dei prossimi anni, troveranno **TECNOLOGIE FRB** comparsa attiva e all'avanguardia.

***TECNOLOGIE FRB** designs, manufactures and markets many different patented product lines that are truly innovative and incorporate advanced technology turning, gear cutting and grinding concepts.*

***TECNOLOGIE FRB** have invested heavily in Research & Development right from the day they started in early sixties, to ensure their products keep abreast of the latest technological advance and constantly improve their performance.*

This has won them the trust of many leading italian and international companies, who always use their products. They also work closely with the design offices of leading italian and foreign machine tools manufacturers.

***TECNOLOGIE FRB** are going to continue to be at the forefront despite the ever increasing pace of technological change.*

INDICE / CONTENTS

LEGENDA ICONE ICONS KEY	1
CONTROPUNTE A CARICO ASSIALE DIFFERENZIATO - SERIE 80 LIVE CENTER WITH AXIAL LOAD DISTRIBUTION - 80 SERIES	4-5
CONTROPUNTE A CARICO ASSIALE DIFFERENZIATO - SERIE 85 LIVE CENTER WITH AXIAL LOAD DISTRIBUTION - 85 SERIES	6-7
CONTROPUNTA A CARICO ASSIALE DIFFERENZIATO PORTA ANELLI CONICI PER TORNITURA DI TUBI - SERIE 80-T / 85-T LIVE CENTER WITH AXIAL LOAD DISTRIBUTION HEADS CARRYING FOR PIPES TURNING - 80-T / 85-T SERIES	8
CONTROPUNTA ROTANTE MOLLEGGIATA - SERIE 81 / SERIE 81 RINFORZATA SPRUNG LIVE CENTER - 81 SERIES / 81 REINFORCED SERIES	9
CONTROPUNTE PER TORNITURA DEL TEMPRATO - SERIE 2008 LIVE CENTERS FOR HARD TURNING - 2008 SERIES	10
CONTROPUNTE PER TORNITURA AD ALTE VELOCITÀ - SERIE 2006 HIGH SPEED TURNING LIVE CENTERS - 2006 SERIES	11
CONTROPUNTE PER TORNITURA - SERIE 2000 ECOLINE e PER TORNITURA TUBI - SERIE 2000-T ECOLINE LIVE CENTERS FOR TURNING - 2000 SERIES ECOLINE and FOR PIPES TURNING - 2000-T SERIES ECOLINE	12-13
CUSPIDI INTERCAMBIABILI PER CONTROPUNTE / PUNTE FISSE - SERIE FR INTERCHANGEABLE CENTERS FOR LIVE CENTERS / DEAD CENTERS - FR SERIES	14-15
CONTROPUNTE ROTANTI PER RETTIFICA - SERIE 92 LIVE CENTERS FOR GRINDING - 92 SERIES	16-17
CONTROPUNTE PORTA CUSPIDI PER RETTIFICA - SERIE 92F CENTERS CARRYING LIVE CENTERS FOR GRINDING - 92F SERIES	18
CONTROPUNTE PORTA ANELLI CONICI PER RETTIFICA TUBI - SERIE 92M HEAD CARRYING LIVE CENTER FOR PIPES GRINDING - 92M SERIES	19
CONTROPUNTE ROTANTI PER DENTATURA - SERIE 82 LIVE CENTER FOR GEAR CUTTING MACHINE - 82 SERIES	20
CONTROPUNTE ROTANTI PER DENTATURA TUBI - SERIE 82-T LIVE CENTER FOR PIPES TOOTHING MACHINE - 82-T SERIES	21
CONTROPUNTE ROTANTI PER CARICHI PESANTI PER TORNITURA E RETTIFICA - SERIE 88 / 88-T HEAVY LOADS LIVE CENTERS FOR TURNING AND GRINDING - 88 / 88-T SERIES	22
CONTROPUNTA ROTANTE RINFORZATA A CARICO ASSIALE DIFFERENZIATO - SERIE 86 REINFORCED LIVE CENTER WITH AXIAL LOAD DISTRIBUTION - 86 SERIES	23
CONTROPUNTE ROTANTI "RAPIDO" "RAPIDO" LIVE CENTERS	23
PUNTE FISSE CON FILETTO DI ESTRAZIONE - SERIE PF DEAD CENTERS WITH EXTRACTION THREAD - PF SERIES	24
PUNTE FISSE PORTA ANELLI CONICI CON FILETTO DI ESTRAZIONE PER TORNITURA TUBI - SERIE PF HEAD CARRYING DEAD CENTER WITH EXTRACTION THREAD FOR PIPE TURNING - PF SERIES	25
GHIERA DI ESTRAZIONE PER PUNTE FISSE EXTRACTION NUT FOR DEAD CENTERS	25
CONTROPUNTE FISSE NORMALI CON CUSPIDE IN METALLO DURO A 60° - SERIE PF NORMAL DEAD CENTERS WITH A 60° POINT IN HARD METAL - PF SERIES	26
CONTROPUNTE FISSE PROLUNGATE CON CUSPIDE IN METALLO DURO A 60° - SERIE PF EXTENDED DEAD CENTERS WITH A 60° POINT IN HARD METAL - PF SERIES	27
CONTROPUNTE FISSE CON ANELLO IN METALLO DURO - SERIE PF DEAD CENTERS WITH CARBIDE RING - PF SERIES	28
ANELLI CONICI CON TRE PUNTI DI CONTATTO PER CONTROPUNTE E PUNTE FISSE HEADS WITH THREE CONTACT SECTORS FOR LIVE CENTERS AND DEAD CENTERS	29
ANELLI CONICI PER CONTROPUNTE E PUNTE FISSE HEADS FOR LIVE CENTERS AND DEAD CENTERS	29
DESCRIZIONE FUNZIONALE CONTROPUNTE ROTANTI A CARICO ASSIALE DIFFERENZIATO - SERIE 80 / 85 FUNCTIONAL DESCRIPTION OF LIVE CENTERS WITH AXIAL LOAD DISTRIBUTION - 80 / 85 SERIES	30
APPLICAZIONI PER CONTROPUNTA MOLLEGGIATA SPRUNG LIVE CENTER APPLICATIONS	31
ISTRUZIONI PER L'USO DELLE CONTROPUNTE LIVE CENTERS USE INSTRUCTIONS	32



CONTROPUNTE A CARICO ASSIALE DIFFERENZIATO - SERIE 80 LIVE CENTER WITH AXIAL LOAD DISTRIBUTION - 80 SERIES

80

SERIE SERIES

CONTROPUNTA CON ALBERO INTEGRALE E PUNTA DI METALLO DURO RIPORTATO LIVE CENTER WITH INTEGRAL SHAFT AND CARBIDE TIP INSERT

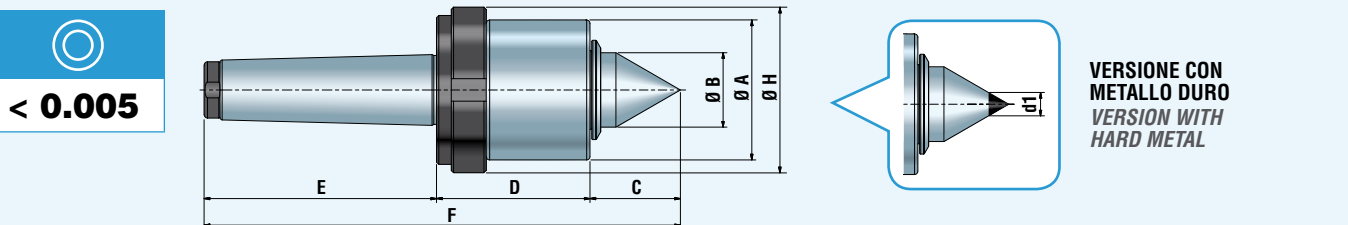

			Dimensioni in mm (pollici) / Dimensions in mm (inch)							
			C	D	E	Ø A	Ø B	F	Ø H	d1
		CM2 / MT2	28 (1.102)	56 (2.205)	67 (2.638)	49 (1.929)	21 (0.827)	151 (5.945)	58 (2.283)	12 (0.472)
		CM3 / MT3	35,5 (1.398)	62,5 (2.461)	83 (3.268)	56,5 (2.224)	29 (1.142)	181 (7.126)	64 (2.520)	12 (0.472)
		CM4 / MT4	40 (1.575)	68 (2.677)	103 (4.055)	62 (2.441)	33 (1.299)	211 (8.307)	74 (2.913)	12 (0.472)
		CM5 / MT5	45 (1.772)	82 (3.228)	136 (5.354)	80 (3.150)	36 (1.417)	263 (10.354)	87 (3.425)	18 (0.709)
		CM6 / MT6	67 (2.638)	122 (4.803)	189 (7.441)	119 (4.685)	57,5 (2.264)	378 (14.882)	130 (5.118)	20 (0.787)

CONTROPUNTA CON ALBERO INTEGRALE PROLUNGATO E PUNTA DI METALLO DURO RIPORTATO LIVE CENTER WITH EXTENDED INTEGRAL SHAFT AND CARBIDE TIP INSERT

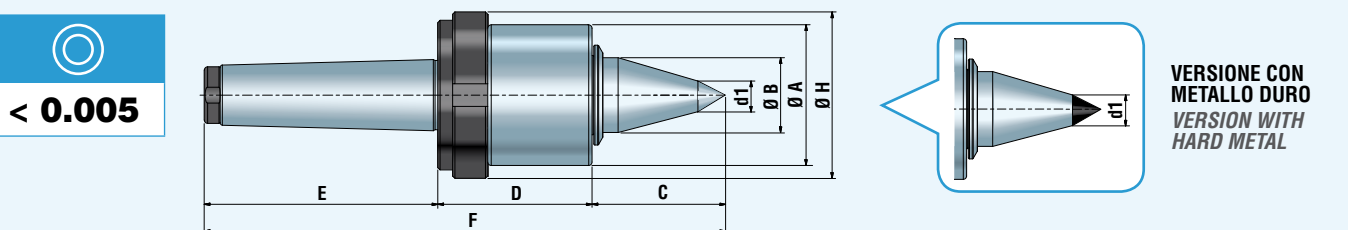

			Dimensioni in mm (pollici) / Dimensions in mm (inch)							
			C	D	E	Ø A	Ø B	F	Ø H	d1
		CM2 / MT2	47 (1.850)	56 (2.205)	67 (2.638)	49 (1.929)	21 (0.827)	170 (6.693)	58 (2.283)	6 (0.236)
		CM3 / MT3	55 (2.165)	62,5 (2.461)	83 (3.268)	56,5 (2.224)	29 (1.142)	200,5 (7.894)	64 (2.520)	10 (0.394)
		CM4 / MT4	60 (2.362)	68 (2.677)	103 (4.055)	62 (2.441)	33 (1.299)	231 (9.094)	74 (2.913)	12 (0.472)
		CM5 / MT5	62 (2.441)	82 (3.228)	136 (5.354)	80 (3.150)	36 (1.417)	280 (11.024)	87 (3.425)	14 (0.551)
		CM6 / MT6	90 (3.543)	122 (4.803)	189 (7.441)	119 (4.685)	57,5 (2.264)	401 (15.787)	130 (5.118)	20 (0.787)

CONTROPUNTA CON ALBERO PORTA CUSPIDE INTERCAMBIABILE LIVE CENTER WITH INTERCHANGEABLE CENTER SUPPORT SHAFT

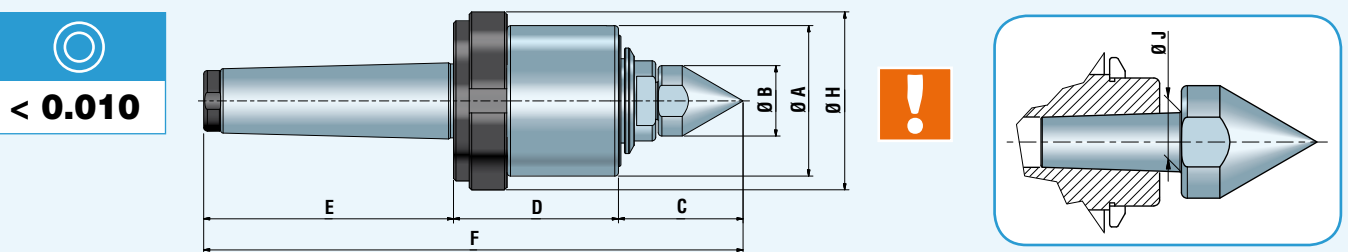

			Dimensioni in mm (pollici) / Dimensions in mm (inch)							
			C	D	E	Ø A	Ø B	F	Ø H	Ø J
		CM2 / MT2	38 (1.496)	56 (2.205)	67 (2.638)	49 (1.929)	21 (0.827)	161 (6.339)	58 (2.283)	CØ13.5
		CM3 / MT3	44 (1.732)	62,5 (2.461)	83 (3.268)	56,5 (2.224)	26 (1.024)	189,5 (7.461)	64 (2.520)	CØ13.5
		CM4 / MT4	48,5 (1.909)	68 (2.677)	103 (4.055)	62 (2.441)	29 (1.142)	219,5 (8.642)	74 (2.913)	CØ15.4
		CM5 / MT5	54 (2.126)	82 (3.228)	136 (5.354)	80 (3.150)	34 (1.339)	272 (10.709)	87 (3.425)	CØ20.3
		CM6 / MT6	65 (2.559)	122 (4.803)	189 (7.441)	119 (4.685)	43 (1.693)	376 (14.803)	130 (5.118)	CØ28



NOTA: Per le cuspidi intercambiabili, vedi paragrafo "serie FR" (vedi pagine 14 e 15).
NOTE: For the interchangeable centers, see "FR series" paragraph (see pages 14 and 15).



DIAGRAMMI DI CARICO LOAD CHARTS

CARICO RADIALE (PESO PEZZO) in kg.
RADIAL LOAD (WORKPIECE WEIGHT) in kg.

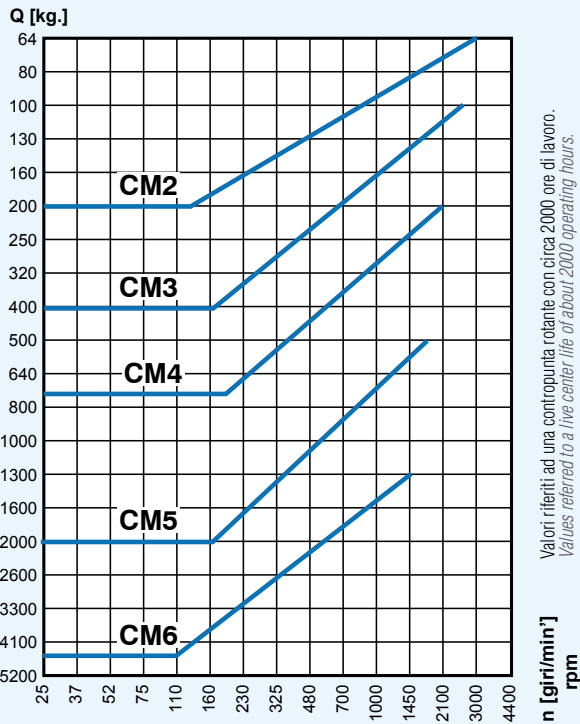

Valori riferiti ad una contropunta rotante con circa 2000 ore di lavoro.
Values referred to a live center life of about 2000 operating hours.

CARICO ASSIALE in kg.
AXIAL LOAD in kg.

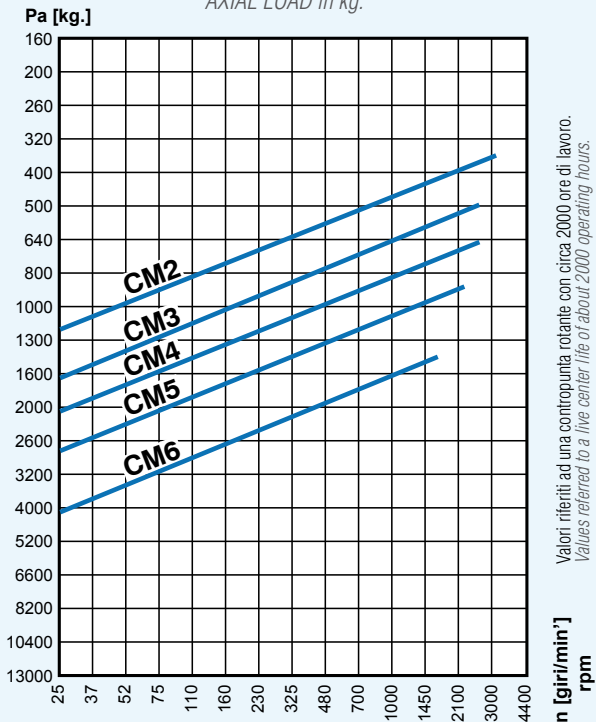

Valori riferiti ad una contropunta rotante con circa 2000 ore di lavoro.
Values referred to a live center life of about 2000 operating hours.

Note: i valori di carico riportati si riferiscono al modello con albero integrale e ad una durata della contropunta di circa 2.000 ore di lavoro.

Le prove hanno comunque dimostrato che si possono ottenere durate superiori o inferiori a seconda delle lavorazioni.

Per gli altri tipi di contropunte (con cuspidi intercambiabile e albero integrale prolungato) è bene ridurre i valori di carico radiale ricavati dal grafico. Tali riduzioni di carico sono dovute nel primo caso all'intercambiabilità della cuspidi e nel secondo al prolungamento dell'albero integrale.

Esempio:

Carichi ammissibili della contropunta CM4 con albero integrale a $n = 1000$ giri/min'
Carico radiale $Q = 320$ kg
Carico assiale $Pa = 900$ kg

Notes: The load values refer to the model with an integral shaft and a live center life of about 2000 operating hours. Tests have shown that the live center can however be used for a longer or shorter period than this, depending on the types of machining task it undertakes.

For other types of live center (with interchangeable center and extended integral shaft) the load values indicated on the graphs should be reduced.

These are a result of the center interchangeability in the first case and in the second are due to the extension of the integral shaft.

Example:

Permitted maximum loads for the MT4 live center with integral shaft at $n = 1000$ r.p.m.
Radial load $Q = 320$ kg
Axial load $Pa = 900$ kg

VALORI INDICATIVI. Per maggiori indicazioni su utilizzo delle contropunte contattare il nostro servizio tecnico.

INDICATIVE VALUES. For further and more detailed information, contact our technical office.



CONTROPUNTE A CARICO ASSIALE DIFFERENZIATO - SERIE 85 LIVE CENTER WITH AXIAL LOAD DISTRIBUTION - 85 SERIES

CONTROPUNTA CON ALBERO INTEGRALE E PUNTA DI METALLO DURO RIPORTATO LIVE CENTER WITH INTEGRAL SHAFT AND CARBIDE TIP INSERT

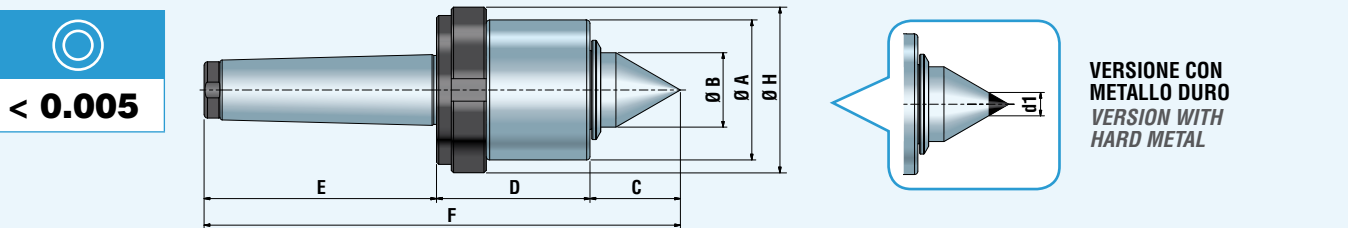

			Dimensioni in mm (pollici) / Dimensions in mm (inch)							
			C	D	E	Ø A	Ø B	F	Ø H	d1
		CM2 / MT2	28 (1.102)	56 (2.205)	67 (2.638)	49 (1.929)	21 (0.827)	151 (5.945)	58 (2.283)	12 (0.472)
		CM3 / MT3	35,5 (1.398)	62,5 (2.461)	83 (3.268)	56,5 (2.224)	29 (1.142)	181 (7.126)	64 (2.520)	12 (0.472)
		CM4 / MT4	40 (1.575)	68 (2.677)	103 (4.055)	62 (2.441)	33 (1.299)	211 (8.307)	74 (2.913)	12 (0.472)
		CM5 / MT5	45 (1.772)	82 (3.228)	136 (5.354)	80 (3.150)	36 (1.417)	263 (10.354)	87 (3.425)	18 (0.709)
		CM6 / MT6	67 (2.638)	122 (4.803)	189 (7.441)	119 (4.685)	57,5 (2.264)	378 (14.882)	130 (5.118)	20 (0.787)

CONTROPUNTA CON ALBERO INTEGRALE PROLUNGATO E PUNTA DI METALLO DURO RIPORTATO LIVE CENTER WITH EXTENDED INTEGRAL SHAFT AND CARBIDE TIP INSERT

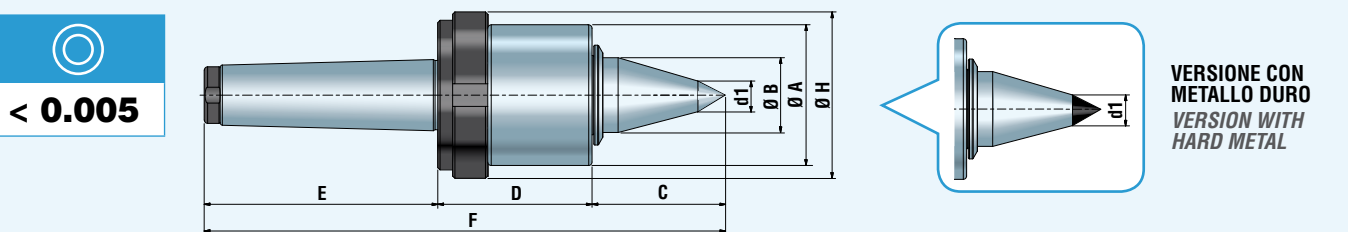

			Dimensioni in mm (pollici) / Dimensions in mm (inch)							
			C	D	E	Ø A	Ø B	F	Ø H	d1
		CM2 / MT2	47 (1.850)	56 (2.205)	67 (2.638)	49 (1.929)	21 (0.827)	170 (6.693)	58 (2.283)	6 (0.236)
		CM3 / MT3	55 (2.165)	62,5 (2.461)	83 (3.268)	56,5 (2.224)	29 (1.142)	200,5 (7.894)	64 (2.520)	10 (0.394)
		CM4 / MT4	60 (2.362)	68 (2.677)	103 (4.055)	62 (2.441)	33 (1.299)	231 (9.094)	74 (2.913)	12 (0.472)
		CM5 / MT5	62 (2.441)	82 (3.228)	136 (5.354)	80 (3.150)	36 (1.417)	280 (11.024)	87 (3.425)	14 (0.551)
		CM6 / MT6	90 (3.543)	122 (4.803)	189 (7.441)	119 (4.685)	57,5 (2.264)	401 (15.787)	130 (5.118)	20 (0.787)

CONTROPUNTA CON ALBERO PORTA CUSPIDE INTERCAMBIABILE LIVE CENTER WITH INTERCHANGEABLE CENTER SUPPORT SHAFT

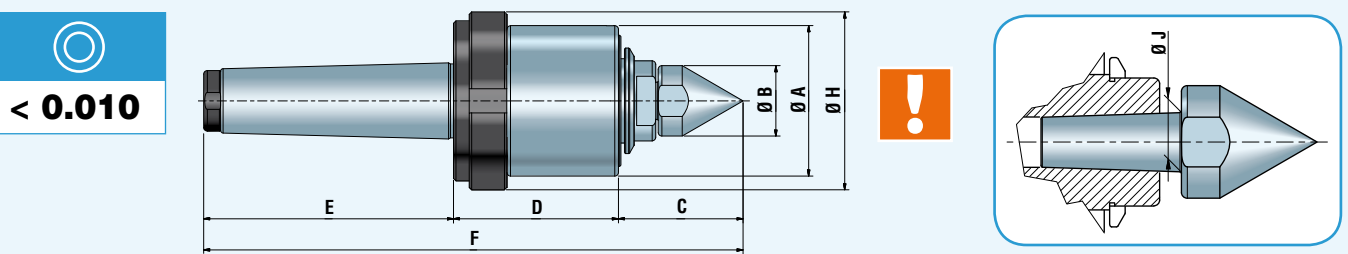

			Dimensioni in mm (pollici) / Dimensions in mm (inch)							
			C	D	E	Ø A	Ø B	F	Ø H	Ø J
		CM2 / MT2	38 (1.496)	56 (2.205)	67 (2.638)	49 (1.929)	21 (0.827)	161 (6.339)	58 (2.283)	CØ13.5
		CM3 / MT3	44 (1.732)	62,5 (2.461)	83 (3.268)	56,5 (2.224)	26 (1.024)	189,5 (7.461)	64 (2.520)	CØ13.5
		CM4 / MT4	48,5 (1.909)	68 (2.677)	103 (4.055)	62 (2.441)	29 (1.142)	219,5 (8.642)	74 (2.913)	CØ15.4
		CM5 / MT5	54 (2.126)	82 (3.228)	136 (5.354)	80 (3.150)	34 (1.339)	272 (10.709)	87 (3.425)	CØ20.3
		CM6 / MT6	65 (2.559)	122 (4.803)	189 (7.441)	119 (4.685)	43 (1.693)	376 (14.803)	130 (5.118)	CØ28

! **NOTA:** Per le cuspidi intercambiabili, vedi paragrafo "serie FR" (vedi pagine 14 e 15).
NOTE: For the interchangeable centers, see "FR series" paragraph (see pages 14 and 15).



DIAGRAMMI DI CARICO LOAD CHARTS

CARICO RADIALE (PESO PEZZO) in kg.
RADIAL LOAD (WORKPIECE WEIGHT) in kg.

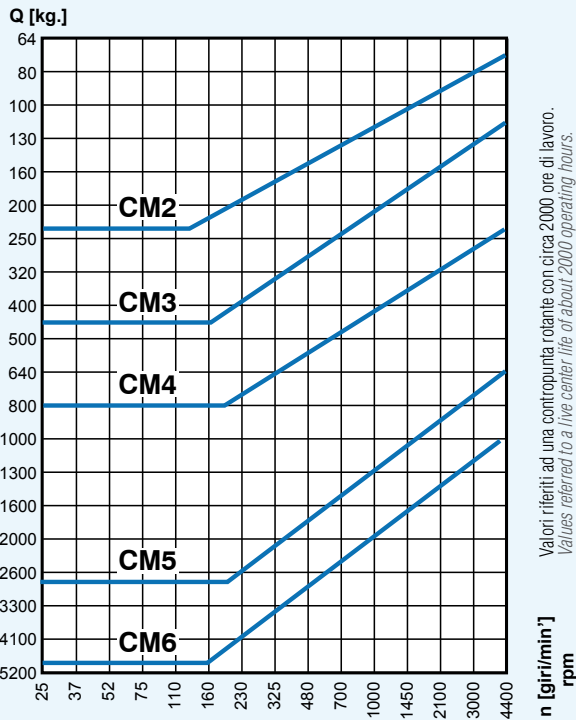

Valori riferiti ad una contropunta rotante con circa 2000 ore di lavoro.
Values referred to a live center life of about 2000 operating hours.

CARICO ASSIALE in kg.
AXIAL LOAD in kg.

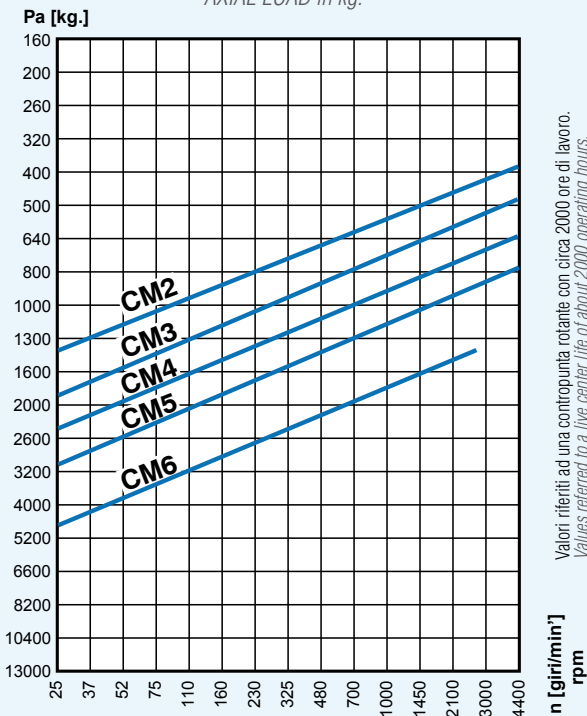

Valori riferiti ad una contropunta rotante con circa 2000 ore di lavoro.
Values referred to a live center life of about 2000 operating hours.

Note: i valori di carico riportati si riferiscono al modello con albero integrale e ad una durata della contropunta di circa 2.000 ore di lavoro.

Le prove hanno comunque dimostrato che si possono ottenere durate superiori o inferiori a seconda delle lavorazioni.

Per gli altri tipi di contropunte (con cuspidi intercambiabile e albero integrale prolungato) è bene ridurre i valori di carico radiale ricavati dal grafico. Tali riduzioni di carico sono dovute nel primo caso all'intercambiabilità della cuspidi e nel secondo al prolungamento dell'albero integrale.

Esempio:

Carichi ammissibili della contropunta CM4 con albero integrale a $n = 1000$ giri/min'
Carico radiale $Q = 450$ kg
Carico assiale $Pa = 900$ kg

Notes: The load values refer to the model with an integral shaft and a live center life of about 2000 operating hours. Tests have shown that the live center can however be used for a longer or shorter period than this, depending on the types of machining task it undertakes.

For other types of live center (with interchangeable center and extended integral shaft) the load values indicated on the graphs should be reduced.

These are a result of the center interchangeability in the first case and in the second are due to the extension of the integral shaft.

Example:

Permitted maximum loads for the MT4 live center with integral shaft at $n = 1000$ r.p.m.
Radial load $Q = 450$ kg
Axial load $Pa = 900$ kg

VALORI INDICATIVI. Per maggiori indicazioni su utilizzo delle contropunte contattare il nostro servizio tecnico.

INDICATIVE VALUES. For further and more detailed information, contact our technical office.



80-T

SERIE
SERIES

CONTROPUNTA A CARICO ASSIALE DIFFERENZIATO PORTA ANELLI CONICI PER TORNITURA DI TUBI - SERIE 80-T LIVE CENTER WITH AXIAL LOAD DISTRIBUTION HEADS CARRYING FOR PIPES TURNING - 80-T SERIES

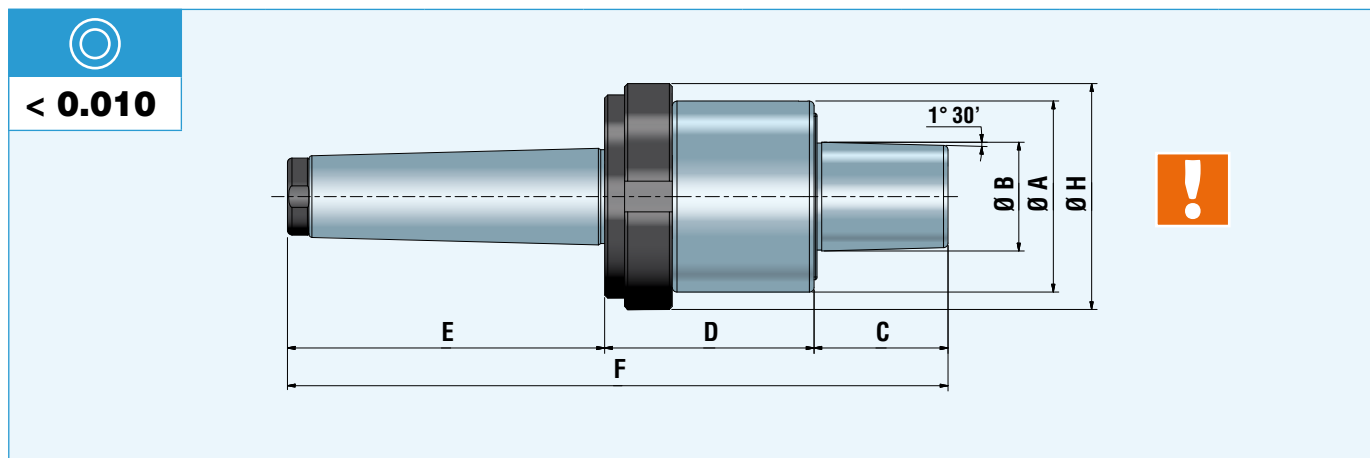

< 0.010



Barcode	Code	Dimensioni in mm (pollici) / Dimensions in mm (inch)						
		C	D	E	Ø A	Ø B	F	Ø H
010180147	CM4 / MT4	42 (1.654)	68 (2.677)	103 (4.055)	62 (2.441)	35 (1.378)	213 (8.386)	74 (2.913)
010180157	CM5 / MT5	42 (1.654)	82 (3.228)	136 (5.354)	80 (3.150)	35 (1.378)	260 (10.236)	87 (3.425)
010180167	CM6 / MT6	43 (1.693)	122 (4.803)	189 (7.441)	119 (4.685)	35 (1.378)	354 (13.937)	130 (5.118)



NOTA: Per anelli conici, vedi paragrafo "serie AC" (vedi pagina 29).
NOTE: For heads, see "AC series" paragraph (see page 29).

85-T

SERIE
SERIES

CONTROPUNTA A CARICO ASSIALE DIFFERENZIATO PORTA ANELLI CONICI PER TORNITURA DI TUBI - SERIE 85-T LIVE CENTER WITH AXIAL LOAD DISTRIBUTION HEADS CARRYING FOR PIPES TURNING - 85-T SERIES

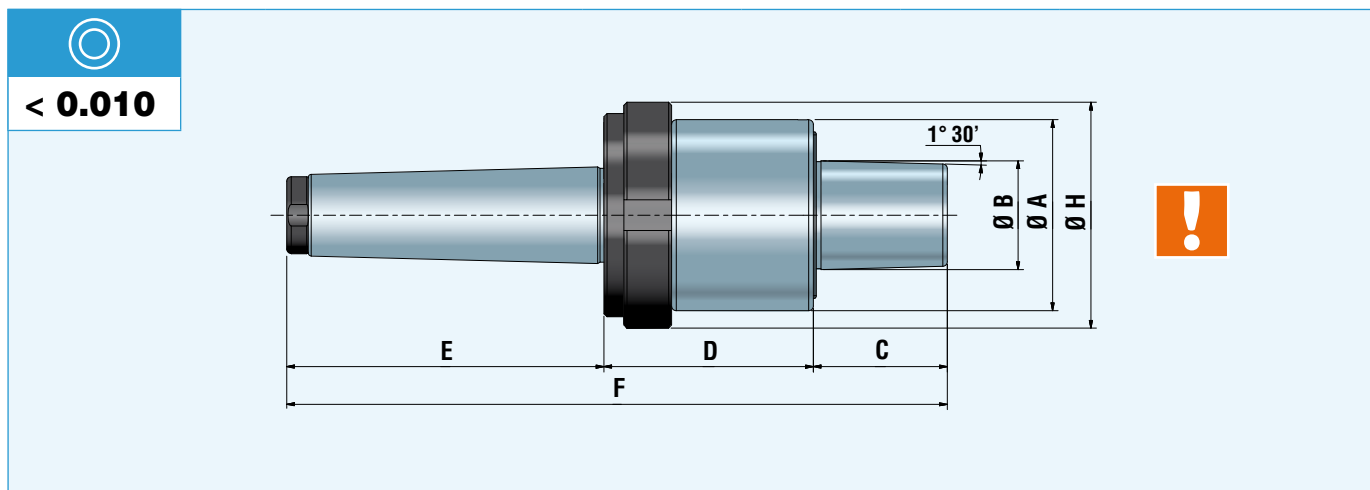

< 0.010



Barcode	Code	Dimensioni in mm (pollici) / Dimensions in mm (inch)						
		C	D	E	Ø A	Ø B	F	Ø H
010185147	CM4 / MT4	42 (1.654)	68 (2.677)	103 (4.055)	62 (2.441)	35 (1.378)	213 (8.386)	74 (2.913)
010185157	CM5 / MT5	42 (1.654)	82 (3.228)	136 (5.354)	80 (3.150)	35 (1.378)	260 (10.236)	87 (3.425)
010185167	CM6 / MT6	43 (1.693)	122 (4.803)	189 (7.441)	119 (4.685)	35 (1.378)	354 (13.937)	130 (5.118)



NOTA: Per anelli conici, vedi paragrafo "serie AC" (vedi pagina 29).
NOTE: For heads, see "AC series" paragraph (see page 29).

CONTROPUNTA ROTANTE MOLLEGGIATA - SERIE 81 SPRUNG LIVE CENTER - 81 SERIES

< 0.010

Y=	
Corsa / Stroke mm (inch)	Carico / Load kg (Lb)
3 (0.118)	90 (198.41)

		Dimensioni in mm (pollici) / Dimensions in mm (inch)		
		Ø C	F	G
010180715	cilindrico / cylindrical	15 h7 (0.591)	123 (4.843)	50 (1.969)
010180819	cilindrico / cylindrical	19,05 h7 (0.750)	123 (4.843)	50 (1.969)
010180925	cilindrico / cylindrical	25,4 h7 (1.000)	123 (4.843)	50 (1.969)
010181001	CM1 / MT1	12,065 (0.475)	133 (5.236)	60 (2.362)
010181102	CM2 / MT2	17,780 (0.700)	144 (5.670)	71 (2.795)
010181203	CM3 / MT3	23,825 (0.938)	161 (6.339)	88 (3.465)
010181304	CM4 / MT4	31,267 (1.231)	173 (6.811)	100 (3.937)

81
SERIE
SERIES

CONTROPUNTA ROTANTE MOLLEGGIATA - SERIE 81 RINFORZATA SPRUNG ROTATING LIVE CENTERS - 81 REINFORCED SERIES

< 0.010

Y=	
Corsa / Stroke mm (inch)	Carico / Load kg (Lb)
1.5 (0.059)	200 (440.92)
3 (0.118)	400 (881.85)
4.5 (0.177)	600 (1322.77)

010180625 - 010180632

Ø H

010180630 - 010180640

Ø H

010181204

Ø H

		Dimensioni in mm (pollici) / Dimensions in mm (inch)					
		Ø A	Ø B	C	D	E	F
010181204	CM3 / MT3	62 (2.441)	29 (1.142)	50 (1.969)	78 (3.071)	88 (3.465)	216 (8.504)

		Dimensioni in mm (pollici) / Dimensions in mm (inch)							
		Ø A	Ø B	C	D	E	F	Ø H	
010180625	cilindrico / cylindrical	62 (2.441)	29 (1.142)	50 (1.969)	75 (2.953)	65 (2.559)	190 (7.480)	25 (0.984)	
010180632	cilindrico / cylindrical	62 (2.441)	29 (1.142)	50 (1.969)	75 (2.953)	65 (2.559)	190 (7.480)	32 (1.260)	

		Dimensioni in mm (pollici) / Dimensions in mm (inch)							
		Ø A	Ø B	C	D	E	F	Ø H	
010180630	VDI 30	68 (2.677)	29 (1.142)	50 (1.969)	85 (3.346)	55 (2.165)	190 (7.480)	30 (1.181)	
010180640	VDI 40	83 (3.268)	29 (1.142)	50 (1.969)	85 (3.346)	63 (2.480)	198 (7.795)	40 (1.575)	

81R
SERIE
SERIES



NOTA: Per le cuspidi intercambiabili, vedi paragrafo "serie FR" (vedi pagine 14 e 15).
NOTE: For the interchangeable centers, see "FR series" paragraph (see pages 14 and 15).



A pagina 31 di questo catalogo è presente un esempio di applicazione della contropunta molleggiata serie 81.
At page 31 of this catalogue there is an example of application of the spring loaded live center 81 series.



CONTROPUNTE PER TORNITURA DEL TEMPRATO - SERIE 2008 LIVE CENTERS FOR HARD TURNING - 2008 SERIES

2008

SERIE SERIES



< 0.005

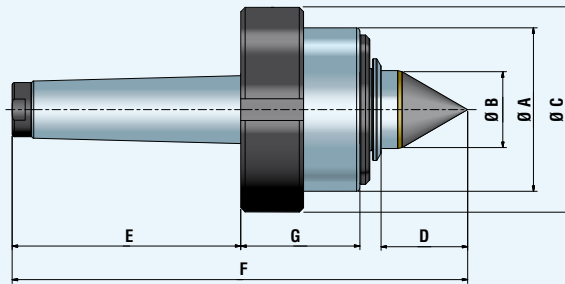

Dimensioni in mm (pollici) / Dimensions in mm (inch)

		Ø A	Ø B	Ø C	D	E	F	G
010108145	CM4 / MT4	75,5 (2.972)	35 (1.378)	95 (3.740)	40 (1.575)	105,5 (4.154)	210,5 (8.287)	55 (2.165)
010108155	CM5 / MT5	75,5 (2.972)	35 (1.378)	95 (3.740)	40 (1.575)	132,5 (5.217)	235 (9.252)	55 (2.165)



< 0.005

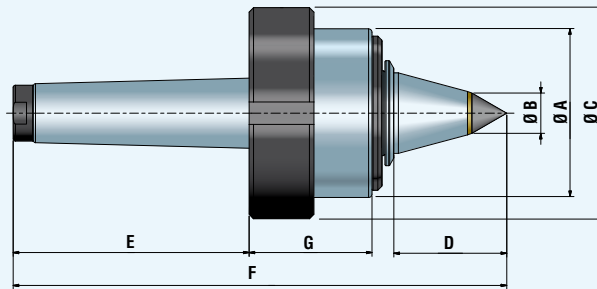

Dimensioni in mm (pollici) / Dimensions in mm (inch)

		Ø A	Ø B	Ø C	D	E	F	G
010108146	CM4 / MT4	75,5 (2.972)	18 (0.709)	95 (3.740)	50,5 (1.988)	105,5 (4.154)	221 (8.701)	55 (2.165)
010108156	CM5 / MT5	75,5 (2.972)	18 (0.709)	95 (3.740)	50,5 (1.988)	132,5 (5.217)	246 (9.685)	55 (2.165)

DIAGRAMMI DI CARICO LOAD CHARTS

Carico radiale (peso pezzo) in kg.
Radial load (workpiece weight) in kg.

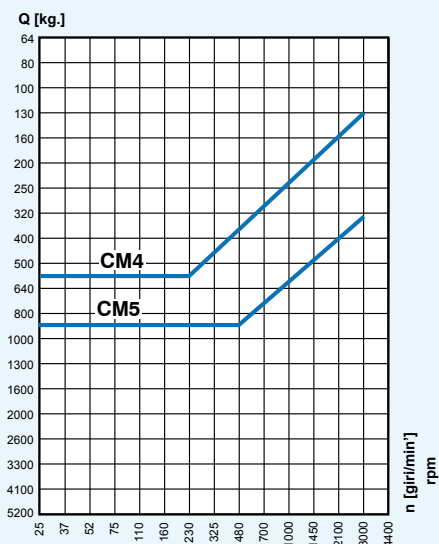

Carico assiale in kg.
Axial load in kg.

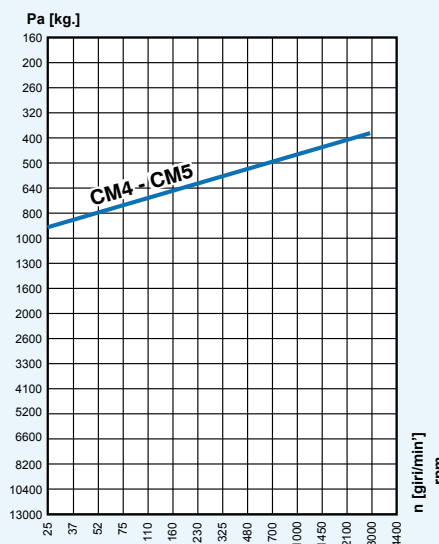

VALORI INDICATIVI. Per maggiori indicazioni su utilizzo delle contropunte contattare il nostro servizio tecnico.

INDICATIVE VALUES. For further and more detailed information, please contact our technical office.

CONTROPUNTE PER TORNITURA AD ALTE VELOCITÀ - SERIE 2006 HIGH SPEED TURNING LIVE CENTERS - 2006 SERIES



< 0.008

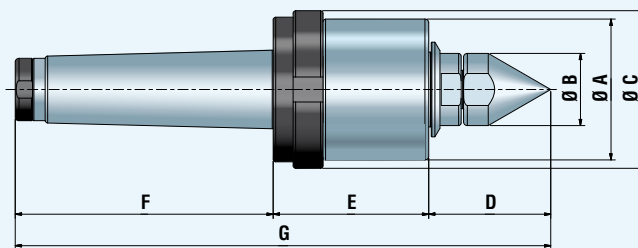

2006

SERIE
SERIES

Dimensioni in mm (pollici) / Dimensions in mm (inch)

		Ø A	Ø B	Ø C	D	E	F	G
010106142	CM4 / MT4	56,5 (2.224)	29 (1.142)	64 (2.520)	48,5 (1.909)	62,4 (2.457)	103,5 (4.075)	214,4 (8.441)
010106152	CM5 / MT5	56,5 (2.224)	29 (1.142)	64 (2.520)	48,5 (1.909)	62,4 (2.457)	103,5 (4.075)	214,4 (8.441)



NOTA: Per le cuspidi intercambiabili, vedi paragrafo "serie FR" (vedi pagine 14 e 15).
NOTE: For the interchangeable centers, see "FR series" paragraph (see pages 14 and 15).

DIAGRAMMI DI CARICO LOAD CHARTS

Carico radiale (peso pezzo) in kg.
Radial load (workpiece weight) in kg.

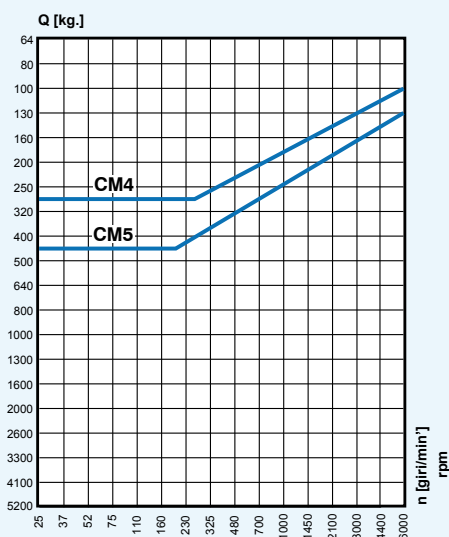

Carico assiale in kg.
Axial load in kg.

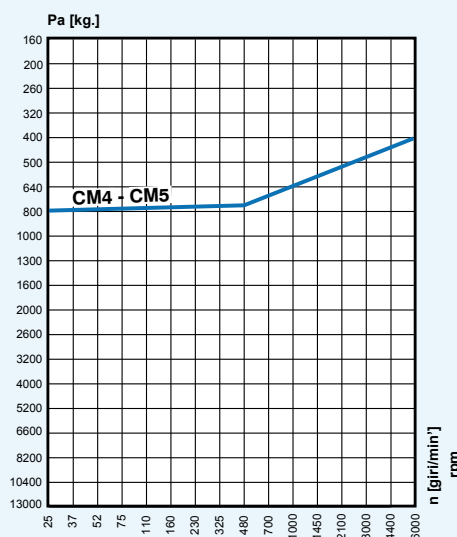

VALORI INDICATIVI. Per maggiori indicazioni su utilizzo delle contropunte contattare il nostro servizio tecnico.

INDICATIVE VALUES. For further and more detailed information, please contact our technical office.



CONTROPUNTE PER TORNITURA - SERIE 2000 ECOLINE LIVE CENTERS FOR TURNING - 2000 SERIES ECOLINE

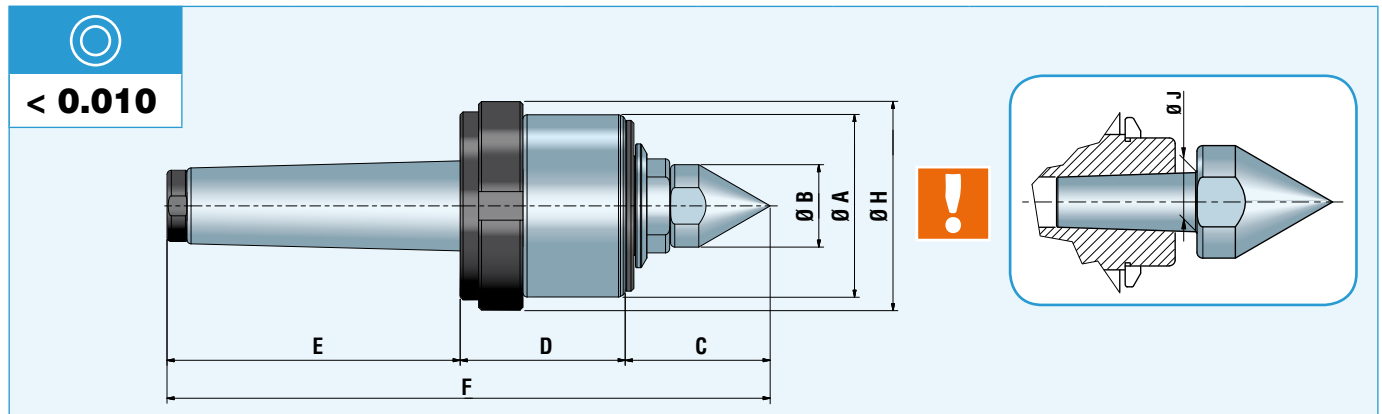

< 0.010

		Dimensioni in mm (pollici) / Dimensions in mm (inch)							
		Ø A	Ø B	C	D	Ø H	E	F	Ø J
010100103	CM3 / MT3	56 (2.205)	26 (1.024)	47 (1.850)	53 (2.087)	64 (2.520)	86 (3.386)	186 (7.323)	CØ13.5
010100104	CM4 / MT4	64 (2.520)	29 (1.142)	51 (2.008)	58 (2.283)	74 (2.913)	103 (4.055)	212 (8.346)	CØ15.4
010100105	CM5 / MT5	78 (3.071)	34 (1.339)	58 (2.283)	64,5 (2.539)	87 (3.425)	136,5 (5.374)	259 (10.197)	CØ20.3



NOTA: Per le cuspidi intercambiabili, vedi paragrafo "serie FR" (vedi pagine 14 e 15).
NOTE: For the interchangeable centers, see "FR series" paragraph (see pages 14 and 15).

CONTROPUNTE PER TORNITURA - SERIE 2000 ECOLINE LIVE CENTERS FOR TURNING - 2000 SERIES ECOLINE

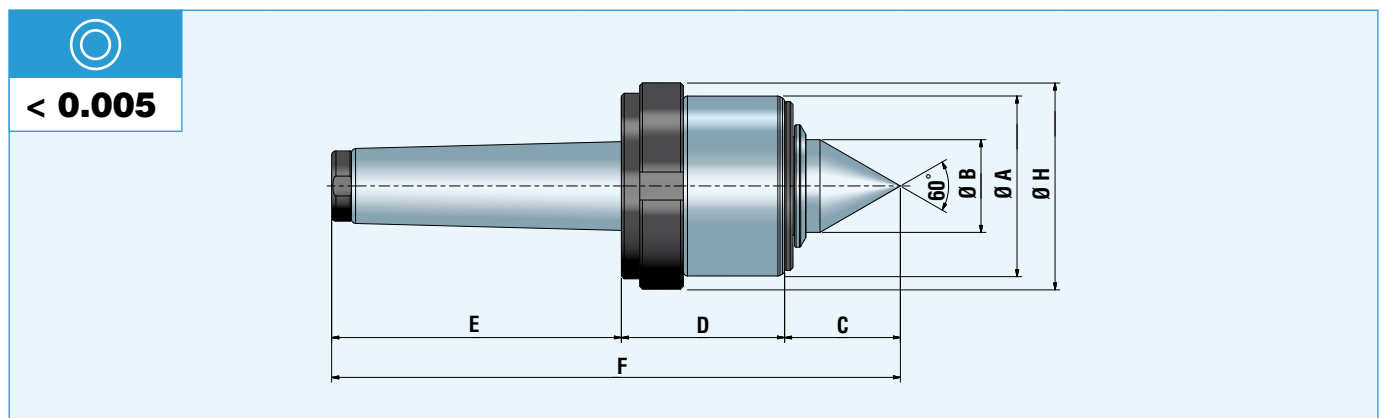

< 0.005

		Dimensioni in mm (pollici) / Dimensions in mm (inch)						
		Ø A	Ø B	C	D	E	F	Ø H
010100123	CM3 / MT3	56 (2.205)	29 (1.142)	37 (1.457)	53 (2.087)	86 (3.386)	176 (6.929)	64 (2.520)
010100124	CM4 / MT4	64 (2.520)	33 (1.299)	41 (1.614)	58 (2.283)	103 (4.055)	202 (7.953)	74 (2.913)
010100125	CM5 / MT5	78 (3.071)	36 (1.417)	47 (1.850)	64,5 (2.539)	136,5 (5.374)	247 (9.724)	87 (3.425)

CONTROPUNTE PER TORNITURA - SERIE 2000 ECOLINE LIVE CENTERS FOR TURNING - 2000 SERIES ECOLINE

2000

SERIE
SERIES

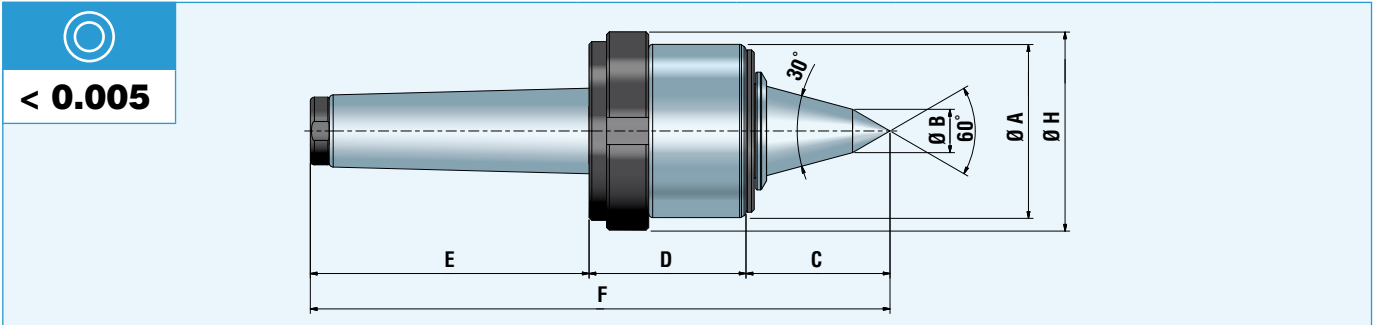

		Dimensioni in mm (pollici) / Dimensions in mm (inch)						
		Ø A	Ø B	C	D	E	F	Ø H
010100113	CM3 / MT3	56 (2.205)	14 (0.551)	47 (1.850)	53 (2.087)	86 (3.386)	186 (7.332)	64 (2.520)
010100114	CM4 / MT4	64 (2.520)	16 (0.630)	53 (2.087)	58 (2.283)	103 (4.055)	214 (8.425)	74 (2.913)
010100115	CM5 / MT5	78 (3.071)	16 (0.630)	66 (2.598)	64,5 (2.539)	136,5 (5.374)	267 (10.512)	87 (3.425)

CONTROPUNTE PER TORNITURA DI TUBI - SERIE 2000-T ECOLINE LIVE CENTERS FOR PIPES TURNING - 2000-T SERIES ECOLINE

2000-T

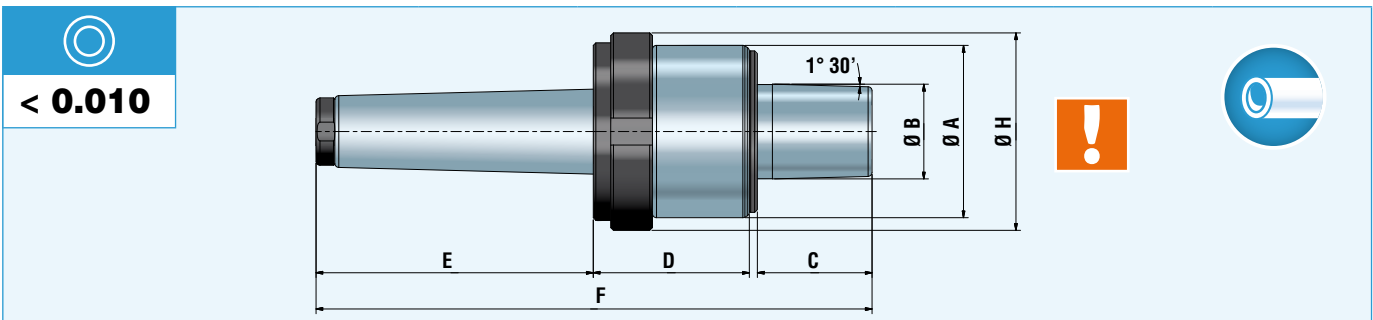

		Dimensioni in mm (pollici) / Dimensions in mm (inch)						
		Ø A	Ø B	C	D	E	F	Ø H
010100134	CM4 / MT4	64 (2.520)	35 (1.378)	43 (1.630)	58 (2.283)	103 (4.055)	207 (8.150)	74 (2.913)
010100135	CM5 / MT5	78 (3.071)	35 (1.378)	44 (1.732)	64,5 (2.539)	136,5 (5.374)	249 (9.803)	87 (3.425)

NOTA: Per anelli conici, vedi paragrafo "serie AC" (vedi pagina 29).
NOTE: For heads, see "AC series" paragraph (see page 29).

DIAGRAMMI DI CARICO LOAD CHARTS

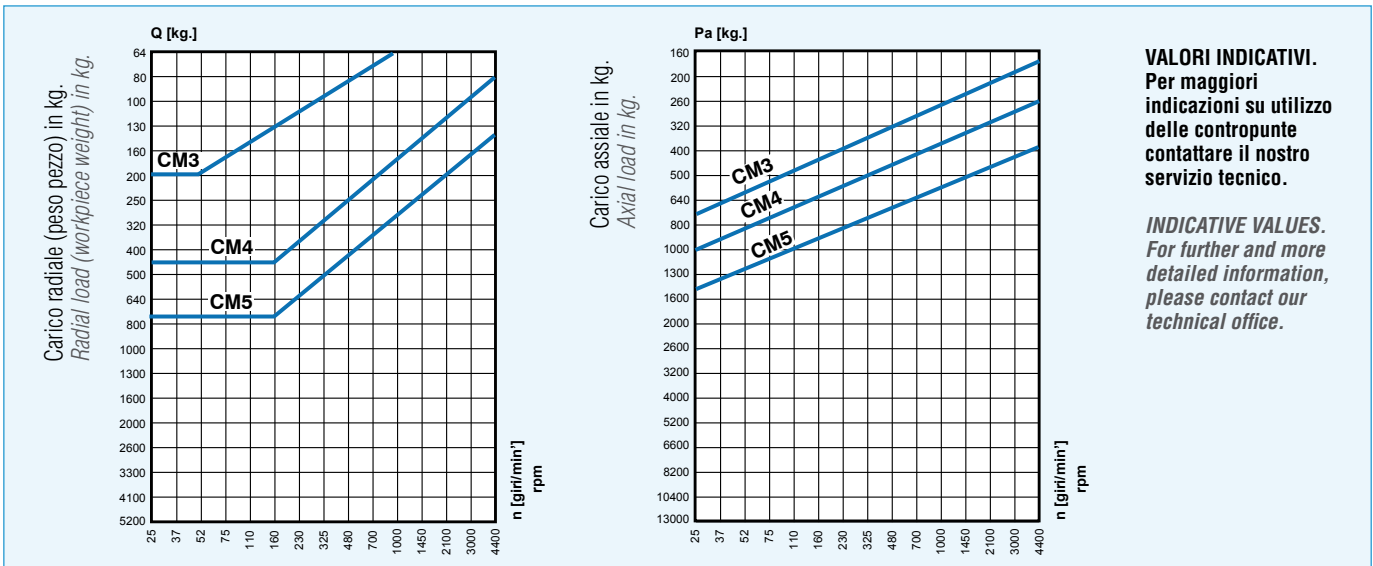



CUSPIDI INTERCAMBIABILI PER CONTROPUNTE / PUNTE FISSE - SERIE FR INTERCHANGEABLE CENTERS FOR LIVE CENTERS / DEAD CENTERS - FR SERIES

TABELLA GENERALE PER L'UTILIZZO DELLE CUSPIDI NELLE VARIE SERIE
GENERAL TABLE FOR THE INTERCHANGEABLE CENTERS USE IN THE VARIOUS SERIES

			80	85	2006	81R	2000
FR 94			•	•	solo cuspidi CØ15,4 centers only	solo cuspidi CØ15,4 centers only	•
FR 95 FR 95 HM			•	•			
FR 96			•	•			
FR 97 FR 97 HM		Ø 7	•	•	solo cuspidi CØ15,4 centers only	solo cuspidi CØ15,4 centers only	•
		Ø 13	•	•	-	-	-
		Ø 15	•	•	solo cuspidi CØ15,4 centers only	solo cuspidi CØ15,4 centers only	•
		Ø 20	•	•	-	-	-
FR 98			•	•	solo cuspidi CØ15,4 centers only	solo cuspidi CØ15,4 centers only	•
FR 98-A			•	•			
FR 99			•	•			

• Verificare nella tabella della relativa contropunta che "Ø J" scegliere.
Check in the table of the related live center which "Ø J" to choose.

FR 95 HM				Dimensioni in mm (pollici) / Dimensions in mm (inch)				
				Ø D	L1	L	Ø J	Ø d1
		030316514	CØ15,4	29 (1.142)	35 (1.378)	29 (1.142)	15,4 (0.606)	14 (0.551)
		030316515	CØ20,3	34 (1.339)	39 (1.535)	30 (1.181)	20,3 (0.799)	16 (0.630)

FR 97 HM				Dimensioni in mm (pollici) / Dimensions in mm (inch)					
				Ø D	L1	L	C	Ø J	Ø d1
		030318514	CØ15,4	29 (1.142)	41,5 (1.634)	29 (1.142)	20 (0.787)	15,4 (0.606)	15 (0.591)
		030318515	CØ20,3	34 (1.339)	46 (1.811)	30 (1.181)	20 (0.787)	20,3 (0.799)	15 (0.591)

FR 94				Dimensioni in mm (pollici) / Dimensions in mm (inch)				
				Ø D	L1	L	Ø J	Ø d1
		030315103	CØ13,5	26 (1.024)	21 (0.827)	28 (1.102)	13,5 (0.531)	13 (0.512)
		030315204	CØ15,4	29 (1.142)	22 (0.866)	29 (1.142)	15,4 (0.606)	15 (0.591)
		030315305	CØ20,3	34 (1.339)	26,5 (1.043)	30 (1.181)	20,3 (0.799)	15 (0.591)
		030315406	CØ28	43 (1.693)	27 (1.063)	40 (1.575)	28 (1.102)	23 (0.906)

CUSPIDI INTERCAMBIABILI PER CONTROPUNTE / PUNTE FISSE - SERIE FR INTERCHANGEABLE CENTERS FOR LIVE CENTERS / DEAD CENTERS - FR SERIES

FR 95			Dimensioni in mm (pollici) / Dimensions in mm (inch)			
			Ø D	L1	L	Ø J
	030316002	CØ13.5	21 (0.827)	26 (1.024)	28 (1.102)	13,5 (0.531)
	030316103	CØ13.5	26 (1.024)	32,5 (1.280)	28 (1.102)	13,5 (0.531)
	030316204	CØ15.4	29 (1.142)	35 (1.378)	29 (1.142)	15,4 (0.606)
	030316305	CØ20.3	34 (1.339)	39,5 (1.555)	30 (1.181)	20,3 (0.799)
	030316406	CØ28	43 (1.693)	47 (1.850)	40 (1.575)	28 (1.102)

FR 96			Dimensioni in mm (pollici) / Dimensions in mm (inch)				
			Ø D	L1	L	Ø J	Ø d1
	030317103	CØ13.5	26 (1.024)	28 (1.102)	28 (1.102)	13,5 (0.531)	5 (0.197)
	030317204	CØ15.4	29 (1.142)	30 (1.181)	29 (1.142)	15,4 (0.606)	6 (0.236)
	030317305	CØ20.3	34 (1.339)	33,5 (1.319)	30 (1.181)	20,3 (0.799)	7 (0.276)
	030317406	CØ28	43 (1.693)	36 (1.417)	40 (1.575)	28 (1.102)	13 (0.512)

FR 97	Ø			Dimensioni in mm (pollici) / Dimensions in mm (inch)					
				Ø D	L1	L	C	Ø J	Ø d1
7		030318103	CØ13.5	26 (1.024)	39,5 (1.555)	28 (1.102)	13 (0.512)	13,5 (0.531)	7 (0.276)
		030318204	CØ15.4	29 (1.142)	42 (1.654)	29 (1.142)	13 (0.512)	15,4 (0.606)	7 (0.276)
		030318305	CØ20.3	34 (1.339)	46 (1.811)	30 (1.181)	13 (0.512)	20,3 (0.799)	7 (0.276)
13		030318406	CØ28	43 (1.693)	61 (2.402)	40 (1.575)	25 (0.984)	28 (1.102)	13 (0.512)
	15	030318113	CØ13.5	26 (1.024)	39,5 (1.555)	28 (1.102)	20 (0.787)	13,5 (0.531)	15 (0.591)
		030318214	CØ15.4	29 (1.142)	42 (1.654)	29 (1.142)	20 (0.787)	15,4 (0.606)	15 (0.591)
030318315		CØ20.3	34 (1.339)	46 (1.811)	30 (1.181)	20 (0.787)	20,3 (0.799)	15 (0.591)	
20		030318416	CØ28	43 (1.693)	61 (2.402)	40 (1.575)	31 (1.220)	28 (1.102)	20 (0.787)

FR 98			Dimensioni in mm (pollici) / Dimensions in mm (inch)				
			Ø D	L1	L	Ø J	Ø d1
	030319103	CØ13.5	53 (2.087)	32,5 (1.280)	28 (1.102)	13,5 (0.531)	25 (0.984)
	030319204	CØ15.4	53 (2.087)	32,5 (1.280)	29 (1.142)	15,4 (0.606)	25 (0.984)
	030319305	CØ20.3	53 (2.087)	32,5 (1.280)	30 (1.181)	20,3 (0.799)	25 (0.984)
	030319406	CØ28	73 (2.874)	35 (1.378)	40 (1.575)	28 (1.102)	42 (1.654)

FR 98-A			Dimensioni in mm (pollici) / Dimensions in mm (inch)				
			Ø D	L1	L	Ø J	Ø d1
	030319113	CØ13.5	83 (3.268)	36,6 (1.441)	28 (1.102)	13,5 (0.531)	50 (1.969)
	030319214	CØ15.4	83 (3.268)	36,6 (1.441)	29 (1.142)	15,4 (0.606)	50 (1.969)
	030319315	CØ20.3	83 (3.268)	36,6 (1.441)	30 (1.181)	20,3 (0.799)	50 (1.969)
	030319416	CØ28	103 (4.055)	36,6 (1.441)	40 (1.575)	28 (1.102)	70 (2.756)

FR 99			Dimensioni in mm (pollici) / Dimensions in mm (inch)				
			Ø D	L1	L	Ø J	Ø d1
	030320103	CØ13.5	24 (0.945)	29 (1.142)	28 (1.102)	13,5 (0.531)	20 (0.787)
	030320204	CØ15.4	27 (1.063)	32 (1.260)	29 (1.142)	15,4 (0.606)	22 (0.866)
	030320305	CØ20.3	34 (1.339)	40 (1.575)	30 (1.181)	20,3 (0.799)	22 (0.866)
	030320406	CØ28	48 (1.890)	46 (1.811)	40 (1.575)	28 (1.102)	40 (1.575)



CONTROPUNTE ROTANTI PER RETTIFICA - SERIE 92 LIVE CENTERS FOR GRINDING - 92 SERIES

ISTRUZIONI PER MANUTENZIONE CONTROPUNTE LUBRIFICATE A GRASSO INSTRUCTIONS FOR MAINTENANCE OF GREASE LUBRICATED LIVE CENTERS

Ogni 150 ore di lavoro lubrificare con GRASSO MOLYKOTE BR 2 PLUS dall'apposito raccordo

Every 150 working hours lubricate with GREASE MOLYKOTE BR 2 PLUS through the suitable fitting.

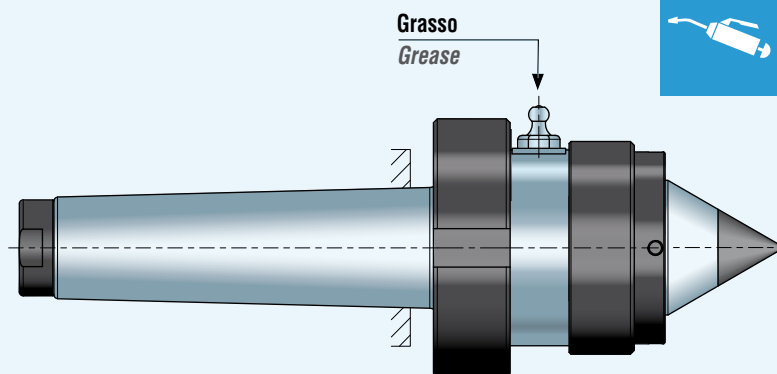

SISTEMA DI LUBRIFICAZIONE AD OLIO NEBULIZZATO OIL MIST LUBRICATION SYSTEM

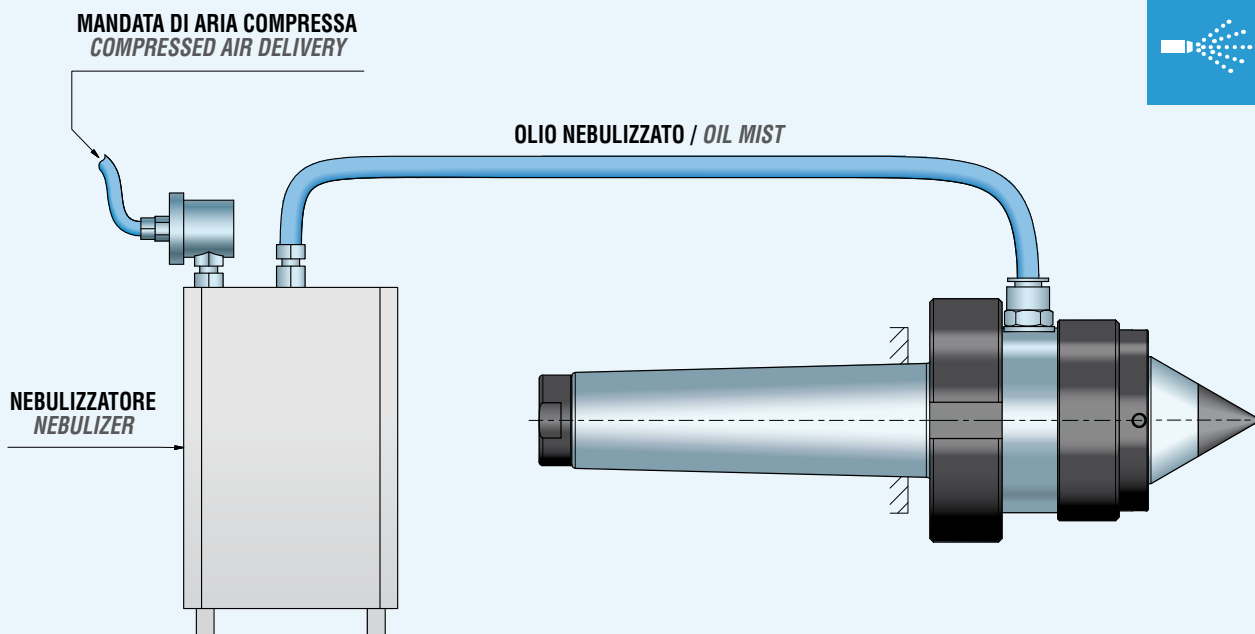

Per un corretto utilizzo si raccomanda che l'impianto di nebulizzazione (non di nostra fornitura) sia esclusivamente per la contropunta.
Oil mist system (not supplied) must be used for the live center only.

Sistemi per lubrificazione contropunta ad olio nebulizzato:

1° tipo: Apparecchio a totale consumo goccia erogata.

Pressione: 1.5 ÷ 2 bar

Gocce di olio al minuto: 2 ÷ 3

2° tipo: Apparecchio con consumo del 10% della goccia erogata e recupero del 90% della stessa.

Pressione: 3 ÷ 4 bar

Gocce di olio al minuto: 20 ÷ 30

(Per la lubrificazione ad olio nebulizzato si raccomanda che il circuito sia esclusivamente per la contropunta).

Olio consigliato Mobil DTE Oil Medium viscosità ISO 46 o DTE Light ISO 32

Oil mist lubrication systems:

1° type: Fixture with total consumption of the delivery drop.

Pressure: 1.5 ÷ 2 bar

Drops of oil per minute: 2 ÷ 3

2° type: Fixture with a 10% consumption of the delivery drop and recovery of 90% of the drop.

Pressure: 3 ÷ 4 bar

Drops of oil per minute: 20 ÷ 30

(Oil mist system must be used for the live center only)

Recommended oil: Mobil DTE Oil Medium viscosity:

ISO 46 or DTE Light ISO 32



CONTROPUNTE ROTANTI PER RETTIFICA - SERIE 92 LIVE CENTERS FOR GRINDING - 92 SERIES

< 0.0025

< 0.0015

Lubrificate a grasso
Grease lubricated

Lubrificazione ad olio nebulizzato
Oil mist lubrication system

			Dimensioni in mm (pollici) / Dimensions in mm (inch)					
			Ø A	Ø B	C	D	E	Ø H
010921101	010921113	CM3/MT3	8 (0.315)	51 (2.008)	25 (0.984)	100 (3.937)	81,7 (3.217)	61 (2.402)
010921102	010921114	CM4/MT4	8 (0.315)	55,5 (2.185)	25 (0.984)	115 (4.528)	102 (4.016)	68 (2.677)
010921103	010921115	CM5/MT5	12 (0.472)	69,5 (2.736)	28,5 (1.122)	129 (5.079)	127 (5.000)	84 (3.307)

< 0.0025

< 0.0015

Lubrificate a grasso
Grease lubricated

Lubrificazione ad olio nebulizzato
Oil mist lubrication system

			Dimensioni in mm (pollici) / Dimensions in mm (inch)					
			Ø A	Ø B	C	D	E	Ø H
010922101	010921123	CM3/MT3	16 (0.630)	51 (2.008)	31,5 (1.240)	100 (3.937)	81,7 (3.217)	61 (2.402)
010922102	010921124	CM4/MT4	16 (0.630)	55,5 (2.185)	31,5 (1.240)	115 (4.528)	102 (4.016)	68 (2.677)
010922103	010921125	CM5/MT5	20 (0.787)	69,5 (2.736)	35,5 (1.398)	129 (5.079)	127 (5.000)	84 (3.307)

< 0.0025

< 0.0015

Lubrificate a grasso
Grease lubricated

Lubrificazione ad olio nebulizzato
Oil mist lubrication system

			Dimensioni in mm (pollici) / Dimensions in mm (inch)					
			Ø A	Ø B	C	D	E	Ø H
010923101	010921133	CM3/MT3	16 (0.630)	51 (2.008)	24,2 (0.953)	83 (3.268)	81,7 (3.217)	61 (2.402)
010923102	010921134	CM4/MT4	20 (0.787)	55,5 (2.185)	31 (1.220)	97 (3.819)	102 (4.016)	68 (2.677)
010923103	010921135	CM5/MT5	26 (1.024)	69,5 (2.736)	42,5 (1.673)	111 (4.370)	127 (5.000)	84 (3.307)



CONTROPUNTE PORTA CUSPIDI PER RETTIFICA - SERIE 92F CENTERS CARRYING LIVE CENTERS FOR GRINDING - 92F SERIES

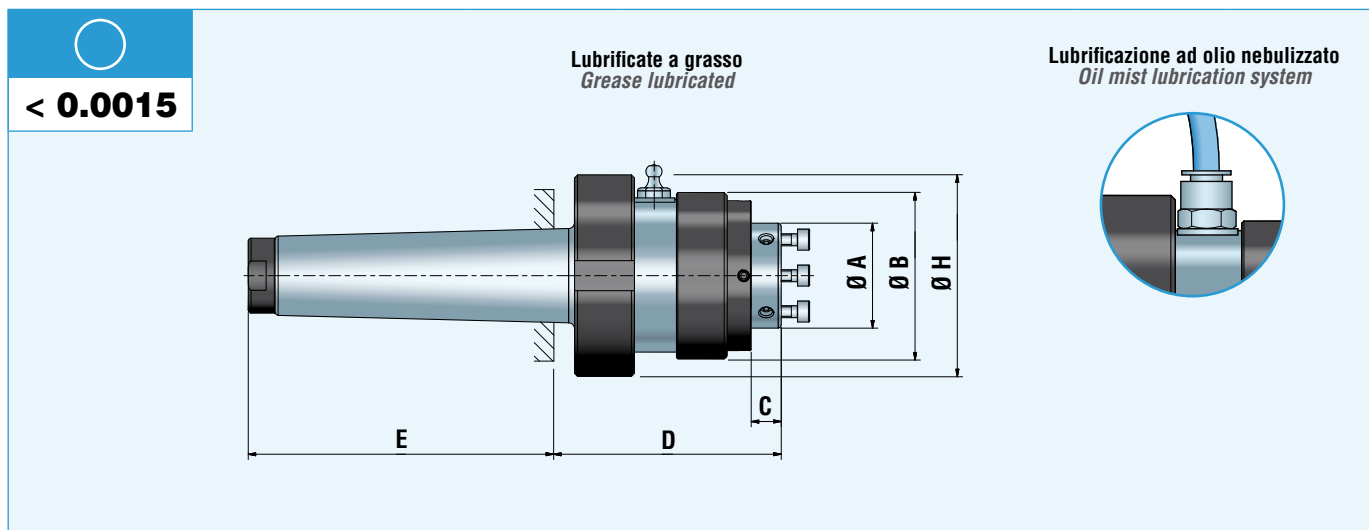

			Dimensioni in mm (pollici) / Dimensions in mm (inch)					
			Ø A	Ø B	C	D	E	Ø H
010925101	010921153	CM3/MT3	32 (1.260)	49 (1.929)	10 (0.394)	68,5 (2.697)	81,7 (3.217)	61 (2.402)
010925102	010921154	CM4/MT4	35 (1.378)	55,5 (2.185)	10 (0.394)	76 (2.992)	102 (4.016)	68 (2.677)
010925103 *	010921155 *	CM5/MT5	48 (1.890)	69,5 (2.736)	10 (0.394)	79 (3.110)	127 (5.000)	84 (3.307)

* Cuspidi per contropunta CM5 disponibili su richiesta
 * Centers for live centers MT5 available on request

CUSPIDI PER CONTROPUNTE PER RETTIFICA SERIE 92F CM3 E CM4 CENTERS FOR LIVE CENTERS FOR GRINDING 92F SERIES MT3 AND MT4

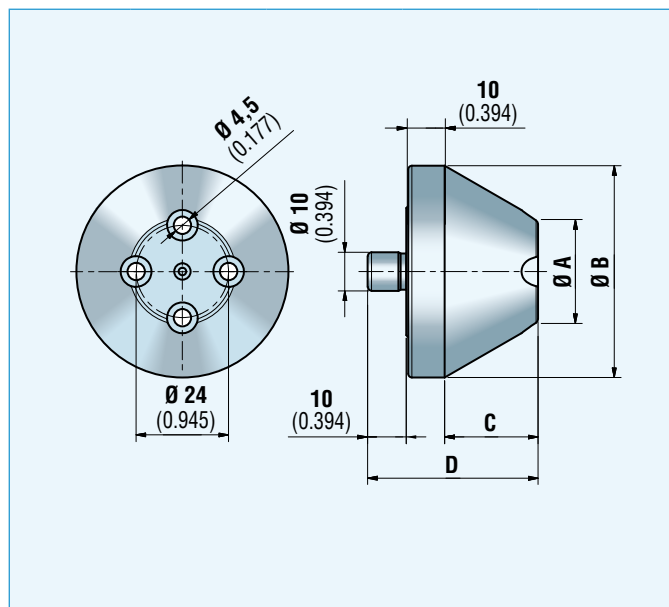

	Dimensioni in mm (pollici) / Dimensions in mm (inch)			
	Ø A	Ø B	C	D
030392005	7 (0.276)	34 (1.339)	23,4 (0.921)	43,4 (1.709)
030392006	27 (1.063)	55 (2.165)	24,2 (0.953)	44,2 (1.740)
030392007	40 (1.575)	68 (2.677)	24,2 (0.953)	44,2 (1.740)
030392008	60 (2.362)	88 (3.465)	24,2 (0.953)	44,2 (1.740)

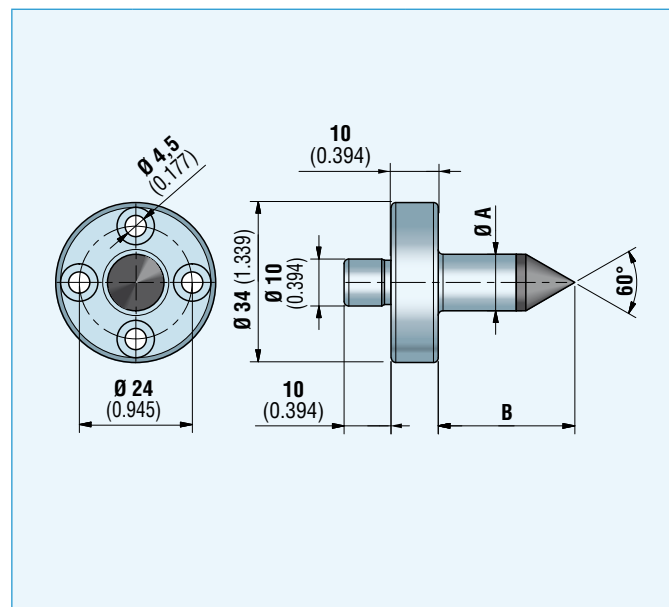

	Dimensioni in mm (pollici) / Dimensions in mm (inch)	
	Ø A	B
030392001	8 (0.315)	25 (0.984)
030392002	10 (0.394)	27 (1.063)
030392003	12 (0.472)	29 (1.142)
030392004	16 (0.630)	32 (1.260)



CONTROPUNTE PORTA ANELLI CONICI PER RETTIFICA TUBI - SERIE 92M HEAD CARRYING LIVE CENTER FOR PIPES GRINDING - 92M SERIES

92M

SERIE
SERIES

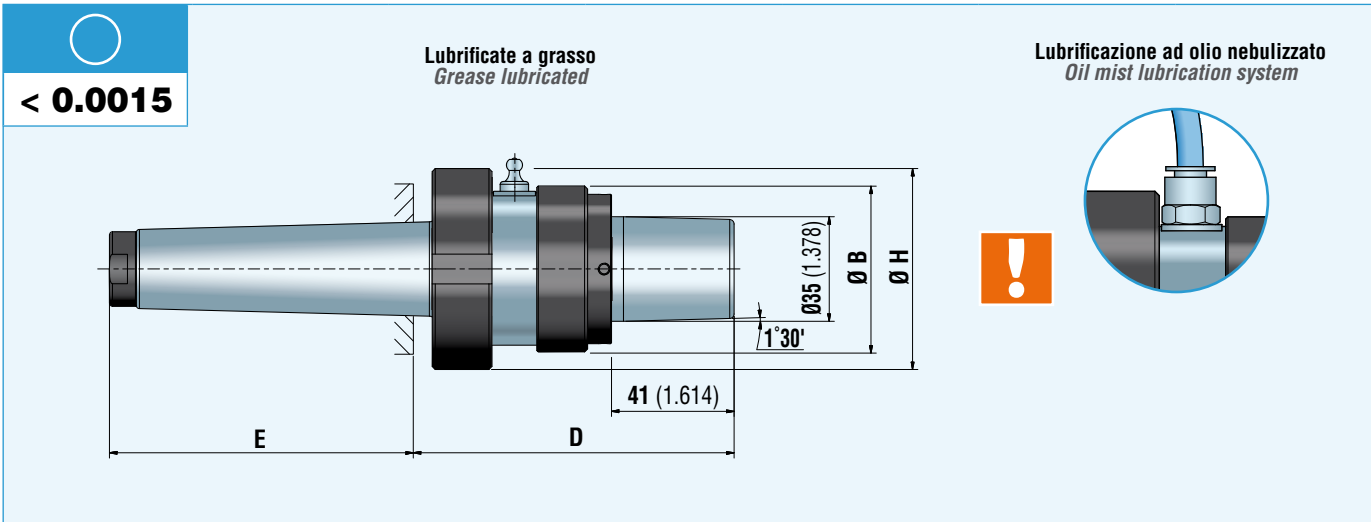

			Dimensioni in mm (pollici) / Dimensions in mm (inch)			
			Ø B	D	E	Ø H
010924102	010921144	CM4/MT4	55,5 (2.185)	107 (4.213)	102 (4.016)	68 (2.677)
010924103	010921145	CM5/MT5	69,5 (2.736)	111 (4.370)	127 (5.000)	84 (3.307)

NOTA: Per anelli conici, vedi paragrafo “serie AC” (vedi pagina 29).
NOTE: For heads, see “AC series” paragraph (see page 29).



CONTROPUNTE ROTANTI PER DENTATURA - SERIE 82 LIVE CENTER FOR GEAR CUTTING MACHINE - 82 SERIES

82

SERIE
SERIES



< 0.005

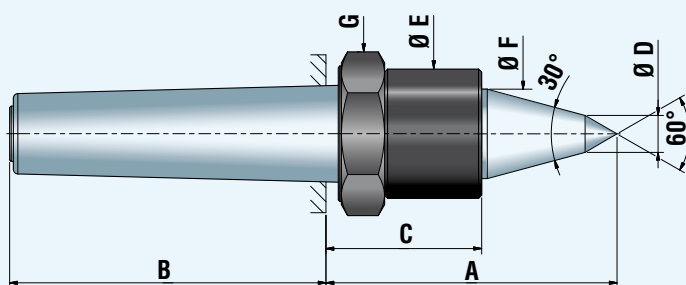

Dimensioni in mm (pollici) / Dimensions in mm (inch)

		A	B	C	Ø D	Ø E	Ø F	G
010182036	CM3 / MT3	93 (3.661)	84,2 (3.315)	49 (1.929)	12 (0.472)	42 (1.654)	29 (1.142)	53 (2.087)
010182046	CM4 / MT4	94,5 (3.720)	102,7 (4.043)	50,5 (1.988)	12 (0.472)	42 (1.654)	29 (1.142)	53 (2.087)
010182056	CM5 / MT5	129 (5.079)	129 (5.079)	57,5 (2.264)	15 (0.591)	62 (2.441)	45 (1.772)	74 (2.913)



< 0.005

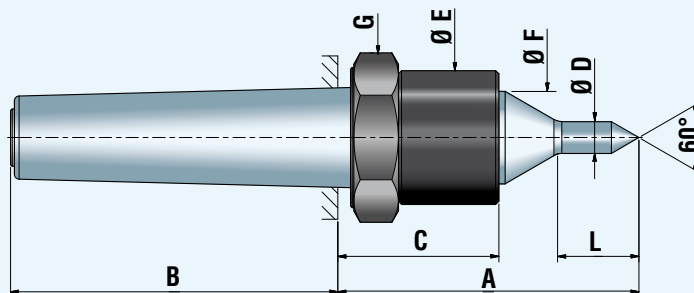

Dimensioni in mm (pollici) / Dimensions in mm (inch)

		A	B	C	Ø D	Ø E	Ø F	G	L
010182034	CM3 / MT3	93 (3.661)	84,2 (3.315)	49 (1.929)	10 (0.394)	42 (1.654)	29 (1.142)	53 (2.087)	25,6 (1.008)
010182035					15 (0.591)				30 (1.181)
010182044	CM4 / MT4	94,5 (3.720)	102,7 (4.043)	50,5 (1.988)	10 (0.394)	42 (1.654)	29 (1.142)	53 (2.087)	25,6 (1.008)
010182045					15 (0.591)				30 (1.181)
010182054	CM5 / MT5	116 (4.567)	129 (5.079)	57,5 (2.264)	10 (0.394)	62 (2.441)	45 (1.772)	74 (2.913)	25,6 (1.008)
010182055					15 (0.591)				30 (1.181)



< 0.005

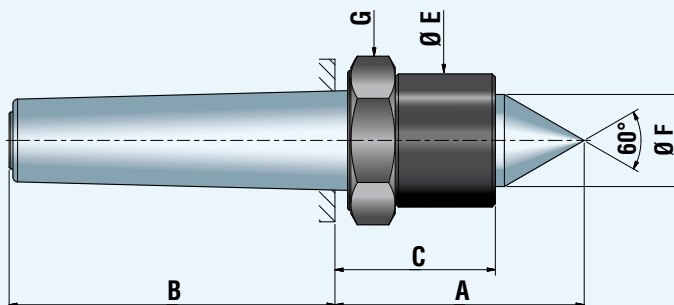

Dimensioni in mm (pollici) / Dimensions in mm (inch)

		A	B	C	Ø E	Ø F	G
010182031	CM3 / MT3	77 (3.031)	84,2 (3.315)	49 (1.929)	42 (1.654)	29 (1.142)	53 (2.087)
010182041	CM4 / MT4	78,5 (3.091)	102,7 (4.043)	50,5 (1.988)	42 (1.654)	29 (1.142)	53 (2.087)
010182051	CM5 / MT5	99 (3.898)	129 (5.079)	57,5 (2.264)	62 (2.441)	45 (1.772)	74 (2.913)



CONTROPUNTE ROTANTI PER DENTATURA TUBI - SERIE 82-T LIVE CENTER FOR PIPES TOOTHING MACHINE - 82-T SERIES

SERIE
SERIES
82-T

< 0.005

		Dimensioni in mm (pollici) / Dimensions in mm (inch)					
		A	B	C	Ø E	Ø F	G
010182037	CM3 / MT3	87,5 (3.445)	84,2 (3.315)	49 (1.929)	25 (0.984)	58 (2.283)	53 (2.087)
010182047	CM4 / MT4	89 (3.504)	102,7 (4.043)	50,5 (1.988)	25 (0.984)	58 (2.283)	53 (2.087)
010182057	CM5 / MT5	96 (3.780)	129 (5.079)	57,5 (2.264)	35 (1.378)	68 (2.677)	74 (2.913)

< 0.010

		Dimensioni in mm (pollici) / Dimensions in mm (inch)					
		A	B	C	Ø E	Ø F	G
010182033	CM3 / MT3	88 (3.465)	84,2 (3.315)	49 (1.929)	42 (1.654)	35 (1.378)	53 (2.087)
010182043	CM4 / MT4	89,5 (3.524)	102,7 (4.043)	50,5 (1.988)	42 (1.654)	35 (1.378)	53 (2.087)
010182053	CM5 / MT5	101 (3.976)	129 (5.079)	57,5 (2.264)	62 (2.441)	35 (1.378)	74 (2.913)

NOTA: Per anelli conici, vedi paragrafo "serie AC" (vedi pagina 29).
NOTE: For heads, see "AC series" paragraph (see page 29).



CONTROPUNTE ROTANTI PER CARICHI PESANTI PER TORNITURA E RETTIFICA - SERIE 88 HEAVY LOADS LIVE CENTER FOR TURNING AND GRINDING - 88 SERIES

88

SERIE
SERIES



< 0.005

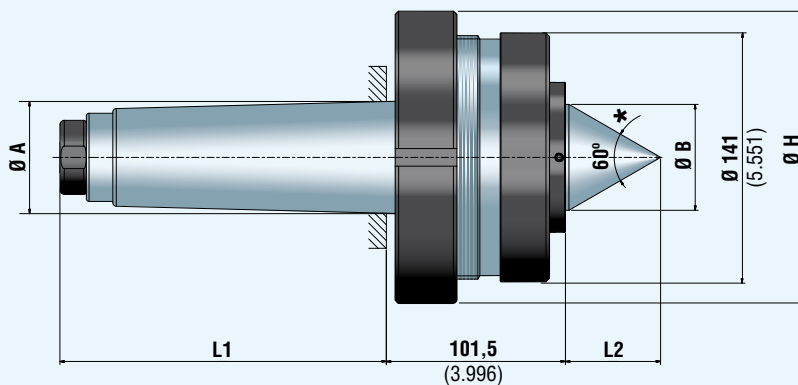

* A RICHIESTA 75°/90°
ON REQUEST 75°/90°

Barcode	Tool Type	Dimensioni in mm (pollici) / Dimensions in mm (inch)					Kg / Lb	Kg / Lb	r.p.m. max.
		A	B	L1	L2	Ø H			
010921104	CM6 / MT6	63,348 (2.494)	60 (2.362)	185 (7.283)	54 (2.126)	166 (6.535)	12.000 / 26,455	9.000 / 19,842	500
010921105	CM7 / MT7	83,061 (3.270)	80 (3.150)	232 (9.134)	71,3 (2.807)	166 (6.535)	12.000 / 26,455	16.000 / 35,274	500
010921106	M80 / MT80	80 (3.150)	80 (3.150)	196 (7.717)	71,3 (2.807)	166 (6.535)	12.000 / 26,455	16.000 / 35,274	500
010921107	M100 / MT100	100 (3.937)	80 (3.150)	232 (9.134)	71,3 (2.807)	166 (6.535)	12.000 / 26,455	16.000 / 35,274	500
010921108	M120 / MT120	120 (4.724)	80 (3.150)	247 (9.724)	70 (2.756)	170 (6.693)	12.000 / 26,455	16.000 / 35,274	500
010921109	M160 / MT160	Su richiesta / on request							

CONTROPUNTE ROTANTI PER CARICHI PESANTI PER TORNITURA E RETTIFICA TUBI - SERIE 88-T HEAVY LOADS LIVE CENTER FOR PIPES TURNING AND GRINDING - 88-T SERIES

88-T

SERIE
SERIES



< 0.010

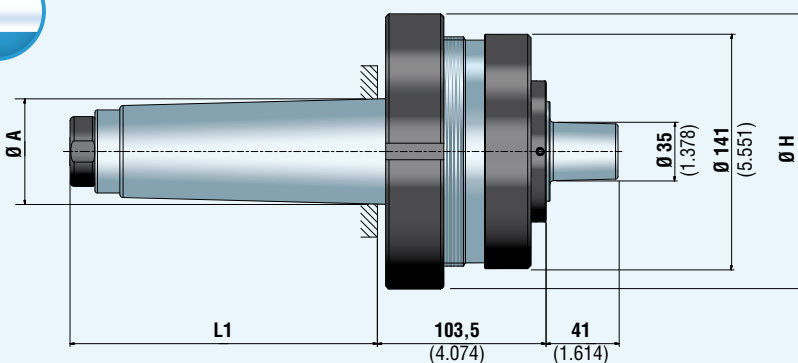

Barcode	Tool Type	Dimensioni in mm (pollici) / Dimensions in mm (inch)			Kg / Lb	Kg / Lb	r.p.m. max.
		A	L1	Ø H			
010922104	CM6 / MT6	63,348 (2.494)	185 (7.283)	166 (6.535)	12.000 / 26,455	9.000 / 19,842	500
010922105	CM7 / MT7	83,061 (3.270)	232 (9.134)	166 (6.535)	12.000 / 26,455	16.000 / 35,274	500
010922106	M80 / MT80	80 (3.150)	196 (7.717)	166 (6.535)	12.000 / 26,455	16.000 / 35,274	500
010922107	M100 / MT100	100 (3.937)	232 (9.134)	166 (6.535)	12.000 / 26,455	16.000 / 35,274	500
010922108	M120 / MT120	120 (4.724)	247 (9.724)	170 (6.693)	12.000 / 26,455	16.000 / 35,274	500



NOTA: Per anelli conici, vedi paragrafo "serie AC" (vedi pagina 29).
NOTE: For heads, see "AC series" paragraph (see page 29).



CONTROPUNTA ROTANTE RINFORZATA A CARICO ASSIALE DIFFERENZIATO - SERIE 86 REINFORCED LIVE CENTER WITH AXIAL LOAD DISTRIBUTION - 86 SERIES

86

SERIE
SERIES

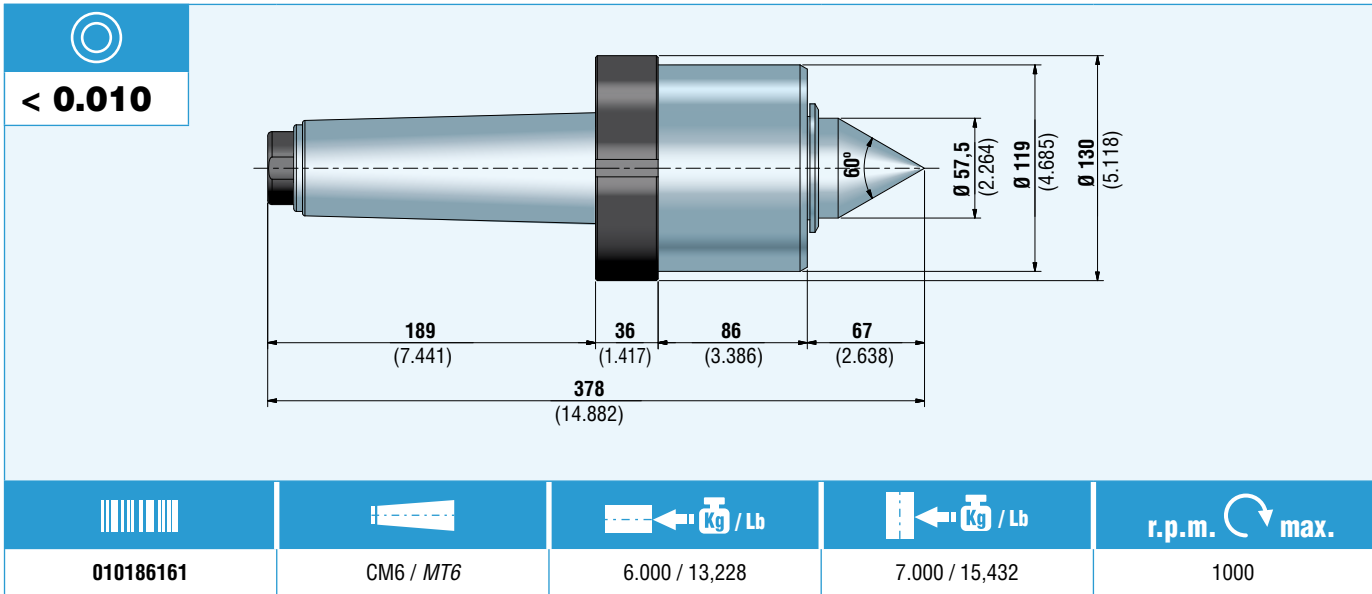

A pagina 30 di questo Catalogo è presente la descrizione funzionale delle contropunte a carico assiale differenziato.
At page 30 of this catalogue there is the functional description of the axial load distribution.



CONTROPUNTE ROTANTI "RAPIDO" "RAPIDO" LIVE CENTERS

RAPIDO

SERIE
SERIES

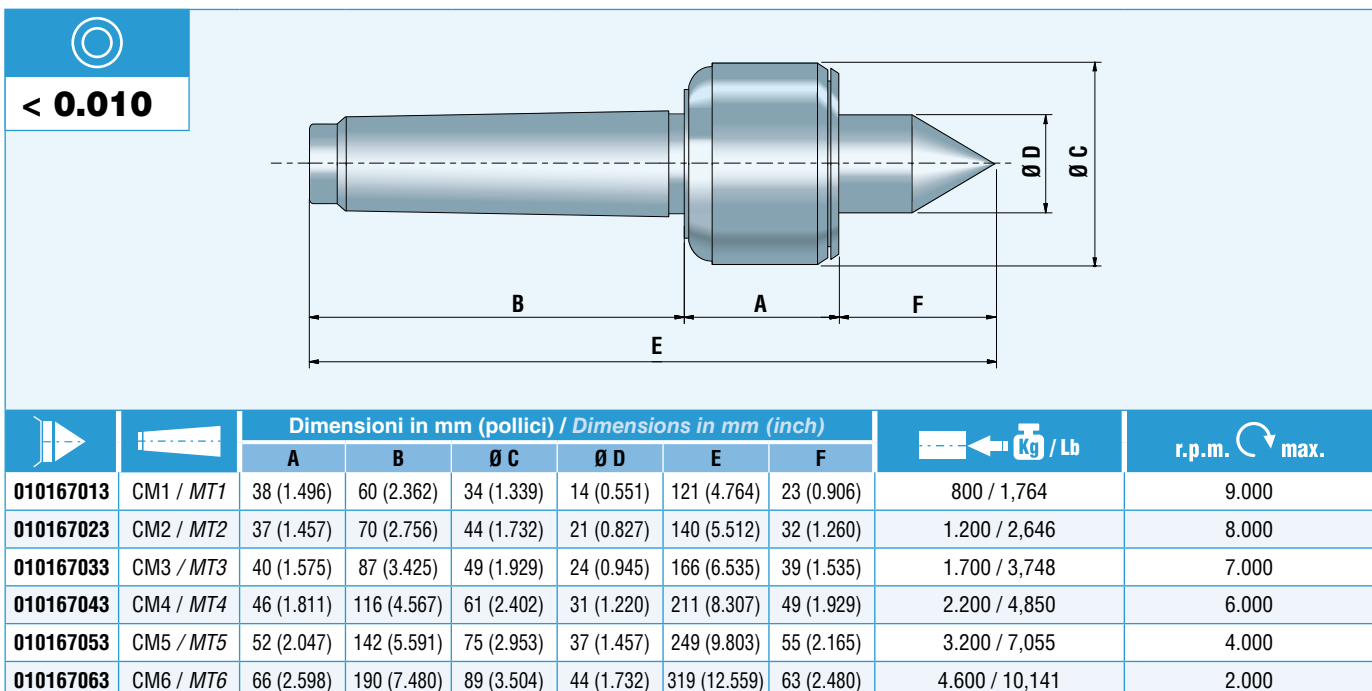



PF

SERIE SERIES

PUNTE FISSE CON FILETTO DI ESTRAZIONE - SERIE PF DEAD CENTERS WITH EXTRACTION THREAD - PF SERIES

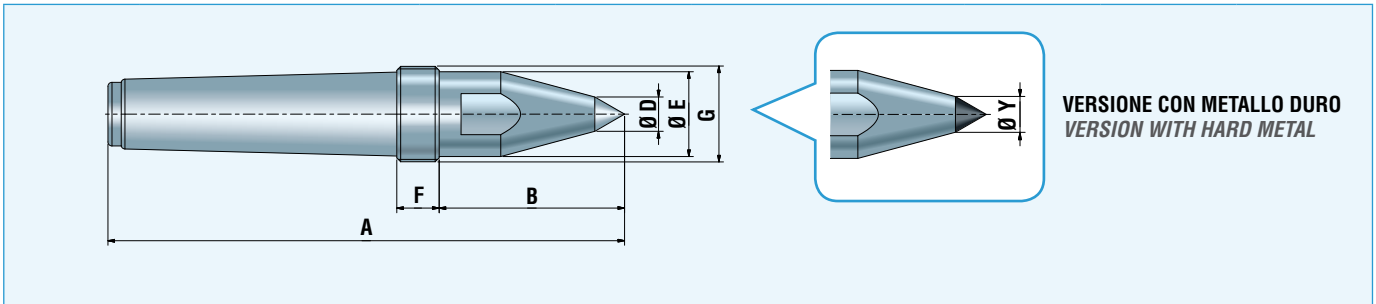

			Dimensioni in mm (pollici) / Dimensions in mm (inch)						Ø Y (H.M.) Ø Y (M.D.)
			A	B	Ø D	Ø E	F	G	
121248003	124100103	CM3 / MT3	145 (5.709)	45 (1.772)	13 (0.512)	24 (0.945)	15 (0.591)	M36 X 1,5	12 (0.472)
121248004	124100104	CM4 / MT4	195 (7.677)	70 (2.756)	13 (0.512)	32 (1.260)	16 (0.630)	M36 X 1,5	14 (0.551)
121248105	124100105	CM5 / MT5	230 (9.055)	74 (2.913)	20 (0.787)	42 (1.654)	16 (0.630)	M48 X 1,5	16 (0.630)

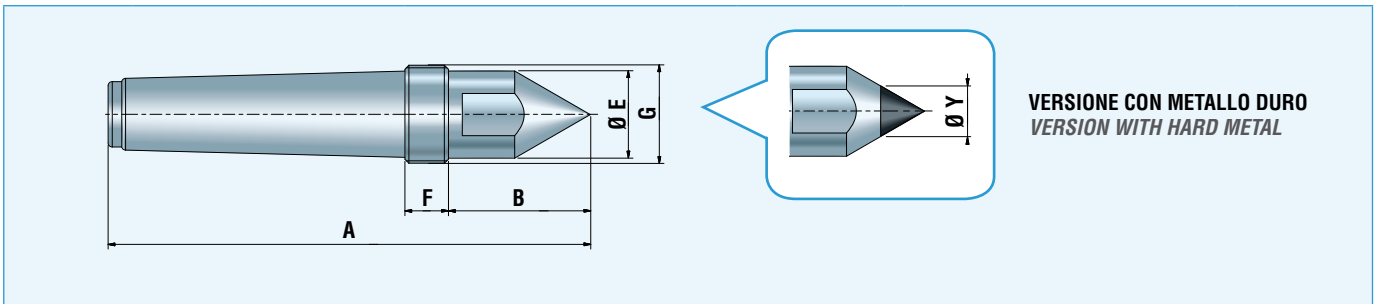

			Dimensioni in mm (pollici) / Dimensions in mm (inch)					Ø Y (H.M.) Ø Y (M.D.)
			A	B	Ø E	F	G	
124300243	124200183	CM3 / MT3	138 (5.433)	38 (1.496)	24 (0.945)	15 (0.591)	M36 X 1,5	18 (0.709)
124300324	124200264	CM4 / MT4	177 (6.969)	52 (2.047)	32 (1.260)	16 (0.630)	M36 X 1,5	26 (1.024)
124300425	124200305	CM5 / MT5	220 (8.661)	64 (2.520)	42 (1.654)	16 (0.630)	M48 X 1,5	30 (1.181)
124300646	-	CM6 / MT6	294 (11.575)	70 (2.756)	64 (2.520)	30 (1.181)	M69 X 2	-
-	124200406	CM6 / MT6	290 (11.417)	80 (3.150)	64 (2.520)	20 (0.787)	M69 X 2	40 (1.575)

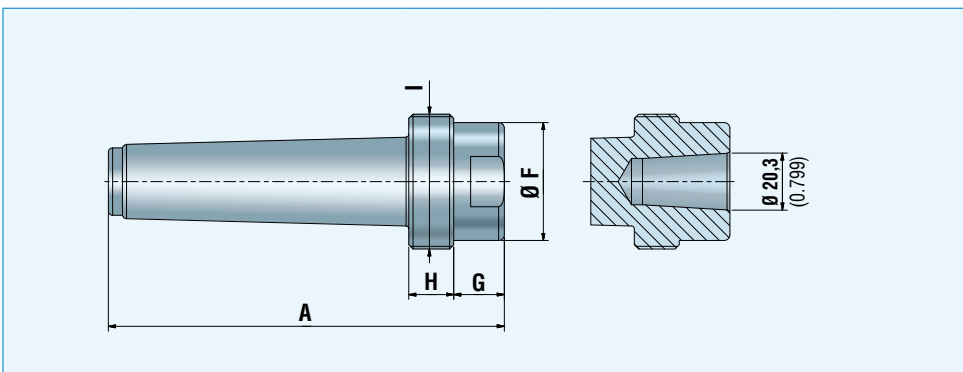

UNICHE CUSPIDI MONTABILI CØ20,3 ONLY MOUNTABLE CENTERS CØ20.3

030315305	FR 94
030316305	FR 95
030317305	FR 96
030318305	FR 97 Ø 7
030318315	FR 97 Ø 15
030319305	FR 98
030319315	FR 98-A
030320305	FR 99



		Dimensioni in mm (pollici) / Dimensions in mm (inch)				
		A	Ø F	G	H	I
122100926	CM3 / MT3	110 (4.331)	42 (1.654)	10 (0.394)	10 (0.394)	M48 X 1,5
122100927	CM4 / MT4	141 (5.551)	42 (1.654)	18 (0.709)	16 (0.630)	M48 X 1,5
122100928	CM5 / MT5	174 (6.850)	42 (1.654)	18 (0.709)	16 (0.630)	M48 X 1,5

NOTA: Punta fissa CM6 porta cuspidi disponibile su richiesta.
NOTE: Center carrying dead center MT6 available on request.

PUNTE FISSE PORTA ANELLI CONICI CON FILETTO DI ESTRAZIONE PER TORNITURA TUBI - SERIE PF HEAD CARRYING DEAD CENTER WITH EXTRACTION THREAD FOR PIPE TURNING - PF SERIES

		Dimensioni in mm (pollici) Dimensions in mm (inch)		
		D2	L	M
123100926	CM3 / MT3	M48 X 1,5	155 (6.102)	14 (0.551)
123100927	CM4 / MT4	M48 X 1,5	180 (7.087)	16 (0.630)
123100928	CM5 / MT5	M48 X 1,5	211 (8.307)	16 (0.630)
123100929	CM6 / MT6	M69 X 2	265 (10.433)	20 (0.787)

PF

SERIE
SERIES

NOTA: Per anelli conici, vedi paragrafo "serie AC" (vedi pagina 29).
NOTE: For heads, see "AC series" paragraph (see page 29).

GHIERA DI ESTRAZIONE PER PUNTE FISSE EXTRACTION NUT FOR DEAD CENTERS

	Dimensioni in mm (pollici) / Dimensions in mm (inch)		
	A	B	C
121249004	50 (1.969)	M36 X 1,5	20 (0.787)
121249105	60 (2.362)	M48 X 1,5	20 (0.787)
121249206	80 (3.150)	M69 X 2	28 (1.102)



CONTROPUNTE FISSE NORMALI CON CUSPIDE IN METALLO DURO A 60° - SERIE PF NORMAL DEAD CENTERS WITH A 60° POINT IN HARD METAL - PF SERIES

Tipo "N" (Normale)
Type "N" (Normal)

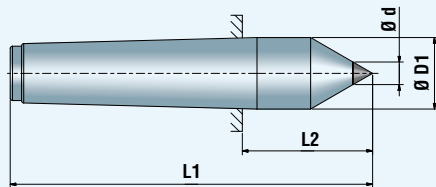

A	Barcode	Dimensioni in mm (pollici) Dimensions in mm (inch)			
		Ø d	Ø D1	L1	L2
1	*191901061	6 (0.236)	12,2 (0.480)	80 (3.150)	26,5 (1.043)
	*191901081	8 (0.315)	12,2 (0.480)	80 (3.150)	26,5 (1.043)
	191901101	10 (0.394)	12,2 (0.480)	80 (3.150)	26,5 (1.043)
2	*191901062	6 (0.236)	18 (0.709)	100 (3.937)	36 (1.417)
	*191901082	8 (0.315)	18 (0.709)	100 (3.937)	36 (1.417)
	*191901102	10 (0.394)	18 (0.709)	100 (3.937)	36 (1.417)
	191901142	14 (0.551)	18 (0.709)	100 (3.937)	36 (1.417)
3	191901182	18 (0.709)	18 (0.709)	100 (3.937)	36 (1.417)
	*191901063	6 (0.236)	24,1 (0.949)	125 (4.921)	44 (1.732)
	*191901083	8 (0.315)	24,1 (0.949)	125 (4.921)	44 (1.732)
	191901103	10 (0.394)	24,1 (0.949)	125 (4.921)	44 (1.732)
	*191901143	14 (0.551)	24,1 (0.949)	125 (4.921)	44 (1.732)
4	*191901183	18 (0.709)	24,1 (0.949)	125 (4.921)	44 (1.732)
	191901233	23 (0.906)	24,1 (0.949)	125 (4.921)	44 (1.732)
	*191901064	6 (0.236)	31,6 (1.244)	160 (6.299)	57,5 (2.264)
	*191901084	8 (0.315)	31,6 (1.244)	160 (6.299)	57,5 (2.264)
	191901104	10 (0.394)	31,6 (1.244)	160 (6.299)	57,5 (2.264)
	*191901144	14 (0.551)	31,6 (1.244)	160 (6.299)	57,5 (2.264)
5	*191901184	18 (0.709)	31,6 (1.244)	160 (6.299)	57,5 (2.264)
	*191901234	23 (0.906)	31,6 (1.244)	160 (6.299)	57,5 (2.264)
	191901304	30 (1.181)	31,6 (1.244)	160 (6.299)	57,5 (2.264)
	*191901125	12 (0.472)	44,7 (1.760)	200 (7.874)	70,5 (2.776)
	*191901165	16 (0.630)	44,7 (1.760)	200 (7.874)	70,5 (2.776)
5	191901205	20 (0.787)	44,7 (1.760)	200 (7.874)	70,5 (2.776)
	*191901265	26 (1.024)	44,7 (1.760)	200 (7.874)	70,5 (2.776)
	191901305	30 (1.181)	44,7 (1.760)	200 (7.874)	70,5 (2.776)

Tipo "N.S." (Normale-Scaricata)
Type "N.S." (Normal-Lowered)

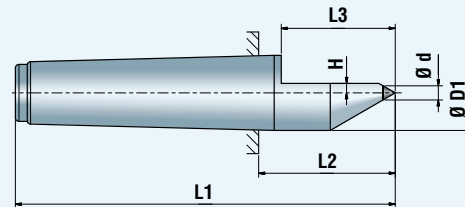

A	Barcode	Dimensioni in mm (pollici) Dimensions in mm (inch)					
		Ø d	Ø D1	L1	L2	L3	H
1	*191902061	6 (0.236)	12,2 (0.480)	80 (3.150)	26,5 (1.043)	20 (0.787)	4 (0.157)
2	191902062	6 (0.236)	18 (0.709)	100 (3.937)	36 (1.417)	29 (1.142)	4 (0.157)
	*191902082	8 (0.315)	18 (0.709)	100 (3.937)	36 (1.417)	29 (1.142)	5 (0.197)
3	191902122	12 (0.472)	18 (0.709)	100 (3.937)	36 (1.417)	29 (1.142)	7 (0.276)
	191902063	6 (0.236)	24,1 (0.949)	125 (4.921)	44 (1.732)	37 (1.457)	4 (0.157)
	*191902083	8 (0.315)	24,1 (0.949)	125 (4.921)	44 (1.732)	37 (1.457)	5 (0.197)
	*191902103	10 (0.394)	24,1 (0.949)	125 (4.921)	44 (1.732)	37 (1.457)	6 (0.236)
4	191902143	14 (0.551)	24,1 (0.949)	125 (4.921)	44 (1.732)	37 (1.457)	8 (0.315)
	191902064	6 (0.236)	31,6 (1.244)	160 (6.299)	57,5 (2.264)	48 (1.890)	4 (0.157)
	*191902084	8 (0.315)	31,6 (1.244)	160 (6.299)	57,5 (2.264)	48 (1.890)	5 (0.197)
	191902124	12 (0.472)	31,6 (1.244)	160 (6.299)	57,5 (2.264)	48 (1.890)	7 (0.276)
	*191902164	16 (0.630)	31,6 (1.244)	160 (6.299)	57,5 (2.264)	48 (1.890)	9 (0.354)
	191902204	20 (0.787)	31,6 (1.244)	160 (6.299)	57,5 (2.264)	48 (1.890)	12 (0.472)
5	191902105	10 (0.394)	44,7 (1.760)	200 (7.874)	70,5 (2.776)	60 (2.362)	6 (0.236)
	*191902145	14 (0.551)	44,7 (1.760)	200 (7.874)	70,5 (2.776)	60 (2.362)	8 (0.315)
	191902185	18 (0.709)	44,7 (1.760)	200 (7.874)	70,5 (2.776)	60 (2.362)	10 (0.394)
	*191902235	23 (0.906)	44,7 (1.760)	200 (7.874)	70,5 (2.776)	60 (2.362)	12,5 (0.492)
	191902305	30 (1.181)	44,7 (1.760)	200 (7.874)	70,5 (2.776)	60 (2.362)	16 (0.630)

*** ATTENZIONE:**
Verificare disponibilità con il nostro ufficio commerciale.

*** WARNING:**
Availability of these items must be verified with our sales department.



A richiesta possiamo realizzare punte fisse speciali, a vostro disegno, con qualsiasi tipo di cono e attacco speciale.
On request we can manufacture special dead centers as per your drawing with every kind of special taper and connection.



CONTROPUNTE FISSE PROLUNGATE CON CUSPIDE IN METALLO DURO A 60° - SERIE PF EXTENDED DEAD CENTERS WITH A 60° POINT IN HARD METAL - PF SERIES

Tipo "P" (Prolungata)
Type "P" (Extended)

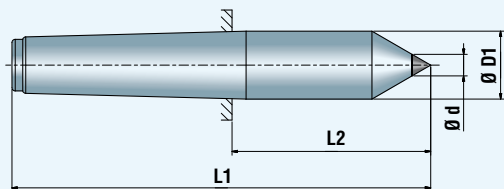

Tipo "P.S." (Prolungata-Scaricata)
Type "P.S." (Extended-Lowered)

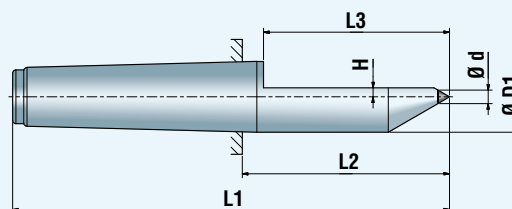

Codice	Barcode	Dimensioni in mm (pollici) Dimensions in mm (inch)			
		Ø d	Ø D1	L1	L2
1	*191903061	6 (0.236)	12,2 (0.480)	100 (3.937)	46,5 (1.831)
	*191903081	8 (0.315)	12,2 (0.480)	100 (3.937)	46,5 (1.831)
	191903101	10 (0.394)	12,2 (0.480)	100 (3.937)	46,5 (1.831)
2	*191903062	6 (0.236)	18 (0.709)	120 (4.724)	56 (2.205)
	*191903082	8 (0.315)	18 (0.709)	120 (4.724)	56 (2.205)
	*191903102	10 (0.394)	18 (0.709)	120 (4.724)	56 (2.205)
	*191903142	14 (0.551)	18 (0.709)	120 (4.724)	56 (2.205)
3	191903182	18 (0.709)	18 (0.709)	120 (4.724)	56 (2.205)
	*191903063	6 (0.236)	24,1 (0.949)	155 (6.102)	74 (2.913)
	*191903083	8 (0.315)	24,1 (0.949)	155 (6.102)	74 (2.913)
	191903103	10 (0.394)	24,1 (0.949)	155 (6.102)	74 (2.913)
	*191903143	14 (0.551)	24,1 (0.949)	155 (6.102)	74 (2.913)
	*191903183	18 (0.709)	24,1 (0.949)	155 (6.102)	74 (2.913)
4	191903233	23 (0.906)	24,1 (0.949)	155 (6.102)	74 (2.913)
	*191903064	6 (0.236)	31,6 (1.244)	195 (7.677)	92,5 (3.642)
	*191903084	8 (0.315)	31,6 (1.244)	195 (7.677)	92,5 (3.642)
	191903104	10 (0.394)	31,6 (1.244)	195 (7.677)	92,5 (3.642)
	*191903144	14 (0.551)	31,6 (1.244)	195 (7.677)	92,5 (3.642)
	*191903184	18 (0.709)	31,6 (1.244)	195 (7.677)	92,5 (3.642)
	*191903234	23 (0.906)	31,6 (1.244)	195 (7.677)	92,5 (3.642)
5	191903304	30 (1.181)	31,6 (1.244)	195 (7.677)	92,5 (3.642)
	*191903125	12 (0.472)	44,7 (1.760)	240 (9.449)	110,5 (4.350)
	*191903165	16 (0.630)	44,7 (1.760)	240 (9.449)	110,5 (4.350)
	191903205	20 (0.787)	44,7 (1.760)	240 (9.449)	110,5 (4.350)
	*191903265	26 (1.024)	44,7 (1.760)	240 (9.449)	110,5 (4.350)
191903305	30 (1.181)	44,7 (1.760)	240 (9.449)	110,5 (4.350)	

Codice	Barcode	Dimensioni in mm (pollici) Dimensions in mm (inch)					
		Ø d	Ø D1	L1	L2	L3	H
1	*191904061	6 (0.236)	12,2 (0.480)	100 (3.937)	46,5 (1.831)	40 (1.575)	4 (0.157)
2	191904062	6 (0.236)	18 (0.709)	120 (4.724)	56 (2.205)	49 (1.929)	4 (0.157)
	*191904082	8 (0.315)	18 (0.709)	120 (4.724)	56 (2.205)	49 (1.929)	5 (0.197)
3	191904122	12 (0.472)	18 (0.709)	120 (4.724)	56 (2.205)	49 (1.929)	7 (0.276)
	191904063	6 (0.236)	24,1 (0.949)	155 (6.102)	74 (2.913)	67 (2.638)	4 (0.157)
	*191904083	8 (0.315)	24,1 (0.949)	155 (6.102)	74 (2.913)	67 (2.638)	5 (0.197)
	*191904103	10 (0.394)	24,1 (0.949)	155 (6.102)	74 (2.913)	67 (2.638)	6 (0.236)
4	191904143	14 (0.551)	24,1 (0.949)	155 (6.102)	74 (2.913)	67 (2.638)	8 (0.315)
	191904064	6 (0.236)	31,6 (1.244)	195 (7.677)	92,5 (3.642)	83 (3.268)	4 (0.157)
	*191904084	8 (0.315)	31,6 (1.244)	195 (7.677)	92,5 (3.642)	83 (3.268)	5 (0.197)
	191904124	12 (0.472)	31,6 (1.244)	195 (7.677)	92,5 (3.642)	83 (3.268)	7 (0.276)
	*191904164	16 (0.630)	31,6 (1.244)	195 (7.677)	92,5 (3.642)	83 (3.268)	9 (0.354)
5	191904204	20 (0.787)	31,6 (1.244)	195 (7.677)	92,5 (3.642)	83 (3.268)	12 (0.472)
	191904105	10 (0.394)	44,7 (1.760)	240 (9.449)	110,5 (4.350)	100 (3.937)	6 (0.236)
	*191904145	14 (0.551)	44,7 (1.760)	240 (9.449)	110,5 (4.350)	100 (3.937)	8 (0.315)
	191904185	18 (0.709)	44,7 (1.760)	240 (9.449)	110,5 (4.350)	100 (3.937)	10 (0.394)
	*191904235	23 (0.906)	44,7 (1.760)	240 (9.449)	110,5 (4.350)	100 (3.937)	12,5 (0.492)
191904305	30 (1.181)	44,7 (1.760)	240 (9.449)	110,5 (4.350)	100 (3.937)	16 (0.630)	

*** ATTENZIONE:**
Verificare disponibilità con il nostro ufficio commerciale.

*** WARNING:**
Availability of these items must be verified with our sales department.



A richiesta possiamo realizzare punte fisse speciali, a vostro disegno, con qualsiasi tipo di cono e attacco speciale.
On request we can manufacture special dead centers as per your drawing with every kind of special taper and connection.



CONTROPUNTE FISSE CON ANELLO IN METALLO DURO - SERIE PF DEAD CENTERS WITH CARBIDE RING - PF SERIES

PF

SERIE
SERIES

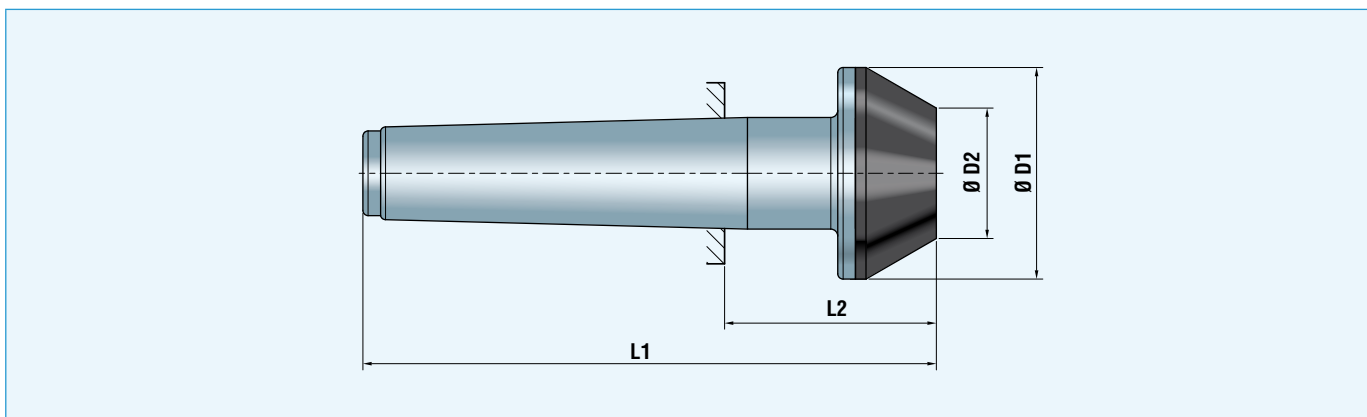

	Barcode	Dimensioni in mm (pollici) Dimensions in mm (inch)			
		Ø D1	Ø D2	L1	L2
2	202030072	30 (1.181)	7 (0.276)	112 (4.409)	48 (1.890)
	202035122	35 (1.378)	12 (0.472)	112 (4.409)	48 (1.890)
	202040172	40 (1.575)	17 (0.669)	112 (4.409)	48 (1.890)
	202045222	45 (1.772)	22 (0.866)	112 (4.409)	48 (1.890)
	202050272	50 (1.969)	27 (1.063)	112 (4.409)	48 (1.890)
3	202030073	30 (1.181)	7 (0.276)	129 (5.079)	48 (1.890)
	202035123	35 (1.378)	12 (0.472)	129 (5.079)	48 (1.890)
	202040173	40 (1.575)	17 (0.669)	129 (5.079)	48 (1.890)
	202045223	45 (1.772)	22 (0.866)	129 (5.079)	48 (1.890)
	202050273	50 (1.969)	27 (1.063)	129 (5.079)	48 (1.890)
	202055323	55 (2.165)	32 (1.260)	129 (5.079)	48 (1.890)
	202060373	60 (2.362)	37 (1.457)	129 (5.079)	48 (1.890)
	202065423	65 (2.559)	42 (1.654)	129 (5.079)	48 (1.890)
	202070473	70 (2.756)	47 (1.850)	129 (5.079)	48 (1.890)
	202075523	75 (2.953)	52 (2.047)	129 (5.079)	48 (1.890)
4	202080573	80 (3.150)	57 (2.244)	129 (5.079)	48 (1.890)
	202085623	85 (3.346)	62 (2.441)	129 (5.079)	48 (1.890)
	202090673	90 (3.543)	67 (2.638)	129 (5.079)	48 (1.890)
	202095723	95 (3.740)	72 (2.835)	129 (5.079)	48 (1.890)
	202000773	100 (3.937)	77 (3.031)	129 (5.079)	48 (1.890)
	202030074	30 (1.181)	7 (0.276)	162 (6.378)	60 (2.362)
	202035124	35 (1.378)	12 (0.472)	162 (6.378)	60 (2.362)
	202040174	40 (1.575)	17 (0.669)	162 (6.378)	60 (2.362)
	202045224	45 (1.772)	22 (0.866)	162 (6.378)	60 (2.362)
	202050274	50 (1.969)	27 (1.063)	162 (6.378)	60 (2.362)

	Barcode	Dimensioni in mm (pollici) Dimensions in mm (inch)			
		Ø D1	Ø D2	L1	L2
4	202055324	55 (2.165)	32 (1.260)	162 (6.378)	60 (2.362)
	202060374	60 (2.362)	37 (1.457)	162 (6.378)	60 (2.362)
	202065424	65 (2.559)	42 (1.654)	162 (6.378)	60 (2.362)
	202070474	70 (2.756)	47 (1.850)	162 (6.378)	60 (2.362)
	202075524	75 (2.953)	52 (2.047)	162 (6.378)	60 (2.362)
	202080574	80 (3.150)	57 (2.244)	162 (6.378)	60 (2.362)
	202085624	85 (3.346)	62 (2.441)	162 (6.378)	60 (2.362)
	202090674	90 (3.543)	67 (2.638)	162 (6.378)	60 (2.362)
	202095724	95 (3.740)	72 (2.835)	162 (6.378)	60 (2.362)
	202000774	100 (3.937)	77 (3.031)	162 (6.378)	60 (2.362)
5	202030075	30 (1.181)	7 (0.276)	200 (7.874)	70,5 (2.776)
	202035125	35 (1.378)	12 (0.472)	200 (7.874)	70,5 (2.776)
	202040175	40 (1.575)	17 (0.669)	200 (7.874)	70,5 (2.776)
	202045225	45 (1.772)	22 (0.866)	200 (7.874)	70,5 (2.776)
	202050275	50 (1.969)	27 (1.063)	200 (7.874)	70,5 (2.776)
	202055325	55 (2.165)	32 (1.260)	200 (7.874)	70,5 (2.776)
	202060375	60 (2.362)	37 (1.457)	200 (7.874)	70,5 (2.776)
	202065425	65 (2.559)	42 (1.654)	200 (7.874)	70,5 (2.776)
	202070475	70 (2.756)	47 (1.850)	200 (7.874)	70,5 (2.776)
	202075525	75 (2.953)	52 (2.047)	200 (7.874)	70,5 (2.776)
5	202080575	80 (3.150)	57 (2.244)	200 (7.874)	70,5 (2.776)
	202085625	85 (3.346)	62 (2.441)	200 (7.874)	70,5 (2.776)
	202090675	90 (3.543)	67 (2.638)	200 (7.874)	70,5 (2.776)
	202095725	95 (3.740)	72 (2.835)	200 (7.874)	70,5 (2.776)
	202000775	100 (3.937)	77 (3.031)	200 (7.874)	70,5 (2.776)



A richiesta possiamo realizzare punte fisse speciali, a vostro disegno, con qualsiasi tipo di cono e attacco speciale.
On request we can manufacture special dead centers as per your drawing with every kind of special taper and connection.



ANELLI CONICI CON 3 PUNTI DI CONTATTO PER CONTROPUNTE E PUNTE FISSE

HEADS WITH THREE CONTACT SECTORS
FOR LIVE CENTERS AND DEAD CENTERS

ANELLI CONICI PER CONTROPUNTE E PUNTE FISSE

HEADS FOR LIVE CENTERS
AND DEAD CENTERS

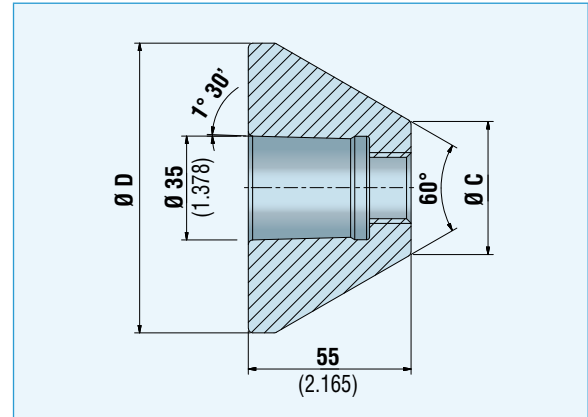
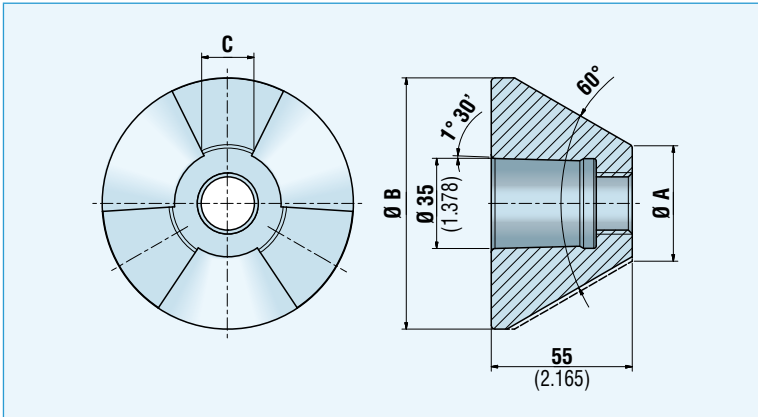

Barcode	Dimensioni in mm (pollici) Dimensions in mm (inch)		
	Ø A	Ø B	C
040300265	45 (1.772)	98 (3.858)	20 (0.787)
040300266	95 (3.740)	148 (5.827)	30 (1.181)
040300267	145 (5.709)	198 (7.795)	40 (1.575)
040300268	195 (7.677)	248 (9.764)	50 (1.969)
040300269	245 (9.646)	298 (11.732)	60 (2.362)

Barcode	Dimensioni in mm (pollici) Dimensions in mm (inch)	
	Ø C	Ø D
Per contropunte con cono CM4-CM5-CM6-CM7-M80-M100 For live centers with MT4-MT5-MT6-MT7-M80-M100 tapers		
040400265	45 (1.772)	98 (3.858)
040400266	95 (3.740)	148 (5.827)
040400267	145 (5.709)	198 (7.795)
040400268	195 (7.677)	248 (9.764)
040400269	245 (9.646)	298 (11.732)
040400270	295 (11.614)	348 (13.701)
040400271	345 (13.583)	398 (15.669)
040400272	395 (15.551)	448 (17.638)
040400273	445 (17.520)	498 (19.606)

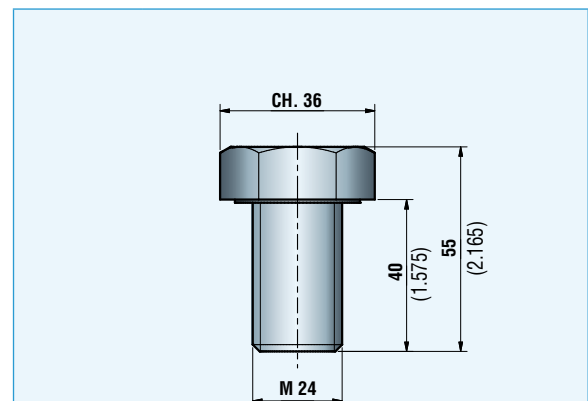
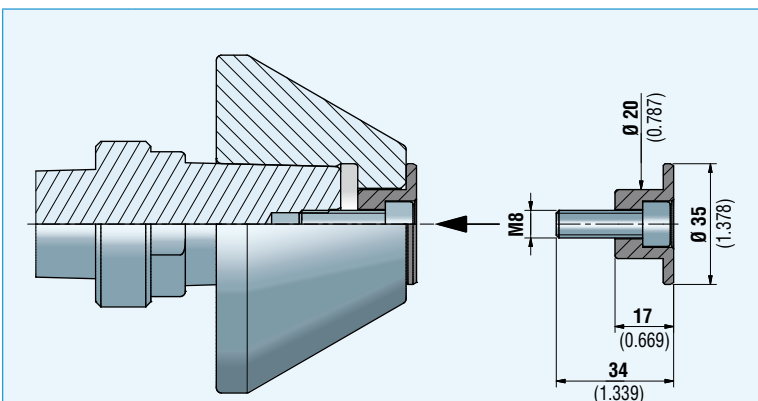

Barcode	Description
012920282	Boccola di sostegno per anelli conici Support bushing for conical heads

Barcode	Description
045000910	Vite TE M24x40 per estrazione anelli conici M24x40 HH screw for heads extraction

DESCRIZIONE FUNZIONALE CONTROPUNTE ROTANTI A CARICO ASSIALE DIFFERENZIATO - SERIE 80 / 85

FUNCTIONAL DESCRIPTION OF LIVE CENTERS WITH AXIAL LOAD DISTRIBUTION - 80 / 85 SERIES

La contropunta FRB a carico assiale differenziato è provvista di due cuscinetti reggispinta **16** e **17** tra i quali è inserita una molla a tazza speciale **5** per differenziare il carico assiale sui due reggispinta. Facendo pressione sulla punta **2**, questa comincia a rientrare fino ad un massimo di 0,25 mm (corrispondenti per la contropunta FRB con morse 4 a 500 kg di carico assiale) che vengono caricati sul reggispinta posteriore **17**.

Pertanto l'albero **3**, essendo già rientrato di 0,25 mm, è andato in battuta sull'anello interno del cuscinetto a rulli conici **14**, trasmettendo così l'ulteriore carico assiale sul reggispinta anteriore **16**. Con questo sistema brevettato, la contropunta consente di lavorare con carico assiale molto elevato e, lavorando con trascinatore, è possibile usare un maggiore avanzamento e profondità di passata.

Vi sono inoltre due gabbie a rullini **18** per una forte tenuta radiale, una boccola anti-vibrante portante **7** mantenuta rigida mediante una molla **8** che ne elimina, in questo modo, le vibrazioni. Agendo con una chiave a compasso sulla ghiera **4** posta anteriormente alla contropunta serie 80, si elimina il gioco che si crea con l'usura dei cuscinetti.

Un anello parascorie di protezione **10** garantisce un perfetto isolamento dell'anello di tenuta **12** dalle scorie stesse.

La ghiera di spallamento ed estrazione **20** nella parte posteriore serve ad eliminare flessioni e vibrazioni.

*The FRB live center with axial load distribution has two thrust bearings **16** and **17** between which a specially designed Belleville spring washer **5** is inserted to distribute the load between the two bearings.*

*When a thrust acts on the center **2**, it will retract up to 0.0098 inches which corresponds to 1,102.3 lb of axial load for the FRB live center Morse taper 4 that is absorbed by the back bearing **17**. As the center shaft **3** has now moved inside by 0.0098 inches, it comes to rest on the inner ring of the cylindrical roller bearing **14**, thereby transmitting the remaining force to the front bearing **16**.*

This patented center allows the center to apply a very high rate of live center thrust to the process. When turning shafts held by face driver, machining can be carried out with an accordingly high feed rate and cutting depth.

*The two roller cages **18** support heavy radial loads and a vibrations damping bush **7** kept stiff by a spring **8** which prevents vibration.*

*The nut **4** at the front of the live center can be adjusted to eliminate the play caused by worn bearings by means of a caliper wrench.*

*A chip guard ring **10** guarantees complete insulation of the sealing ring **12** from chips.*

*The back extraction nut **20** prevents deflection and vibration.*

85

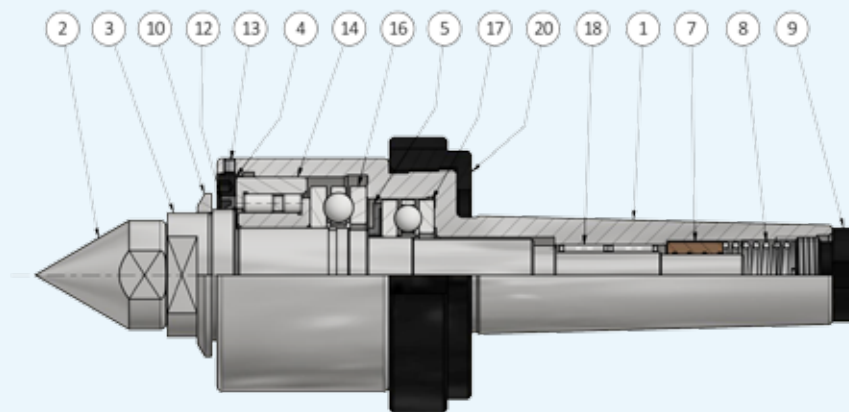

80

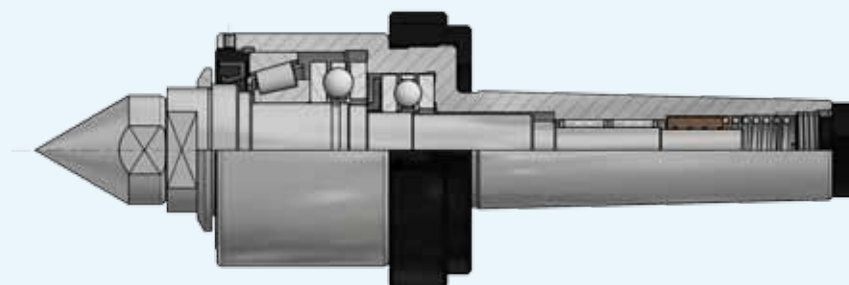

APPLICAZIONI PER CONTROPUNTA MOLLEGGIATA SPRUNG LIVE CENTER APPLICATIONS

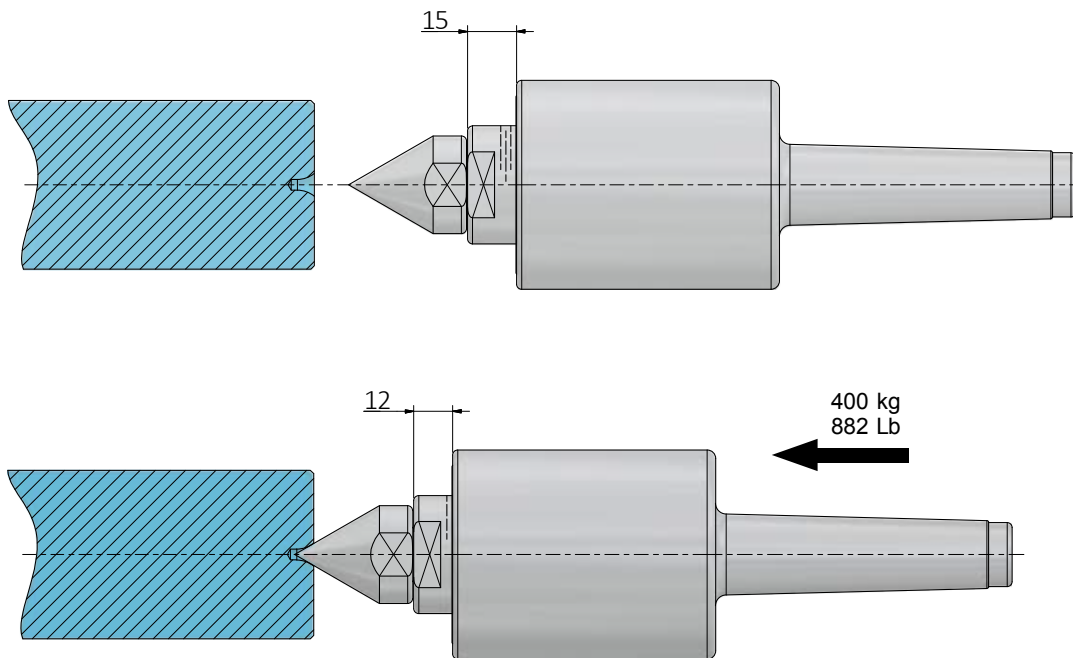
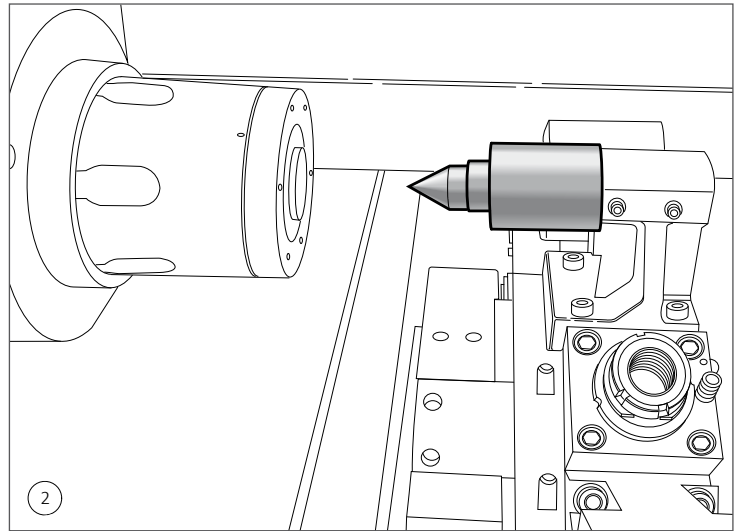
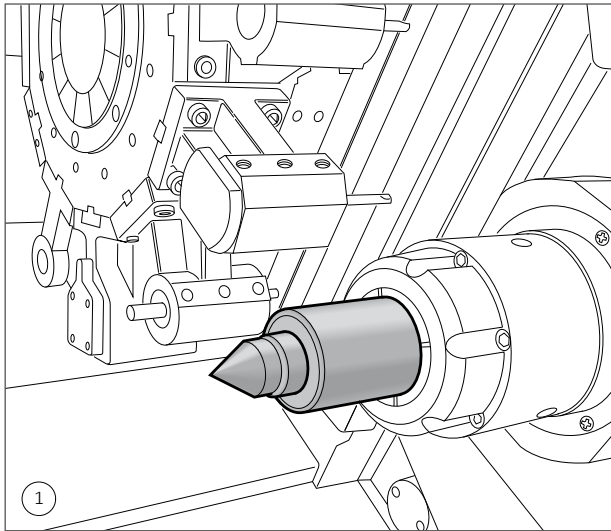

La contropunta molleggiata è nota per poter essere applicata su **contromandrino** (1) e su **torretta porta utensili** (2) in quanto sono questi assi elettrici utilizzati per compiere solo dei posizionamenti e non un continuo controllo della pressione sul pezzo, la contropunta **serie 81** mantiene il pezzo da lavorare continuamente in spinta e lo sviluppo di tale forza sull'albero da tornire avviene tramite lo schiacciamento delle molle a tazza all'interno della contropunta; dopo aver messo a contatto il foro da centro con la cuspidi della contropunta, si fa avanzare la torretta o il contromandrino, tale movimento provoca lo schiacciamento delle molle interne e il conseguente aumento della forza di spinta della contropunta sull'albero in lavorazione, tale aumento della forza è correlato con la variazione della lunghezza Y come da tabella corrispondente.

The spring-loaded live center is known to be applied on the **counter spindle** (1) and on the **tool holder turret** (2) as these electric axes are used to perform only positioning and not a continuous control of the pressure on the piece, the **series 81** live center keeps the workpiece continuously in thrust and the development of this force on the shaft to be turned takes place by pressing the bellville springs inside the live center; after having placed the center hole in contact with the center of the live center, the turret or the counter spindle is advanced, this movement causes the internal springs to be crushed and the consequent increase in the thrust force of the live center on the shaft being processed, this increase of the force is correlated with the variation of the length Y as per the corresponding table.

FUNZIONE DELLA GHIERA DI ESTRAZIONE EXTRACTION NUT FUNCTION

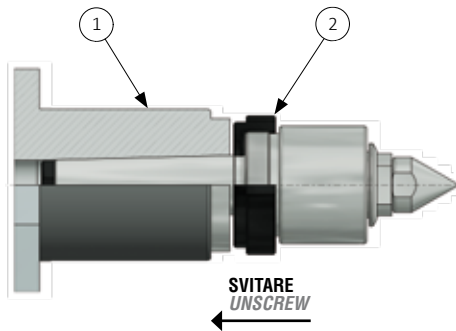

La ghiera avvitata sul fusto serve per favorire l'estrazione della contropunta dal canotto. Utilizzare la ghiera nel seguente modo:

- Svitare la ghiera (2) con l'apposita chiave fino a che la contropunta non viene estratta dal canotto (1).

The extraction nut fitted on the basic body of the live center serves to extract the live center from the tailstock. Use the extraction nut in this way:

- *Unscrew the extraction nut (2) with the specific key until the live center comes out from the tailstock (1).*

MODALITÀ DI ESTRAZIONE DELLA CUSPIDE INTERCAMBIABILE REMOVING THE INTERCHANGEABLE CENTER

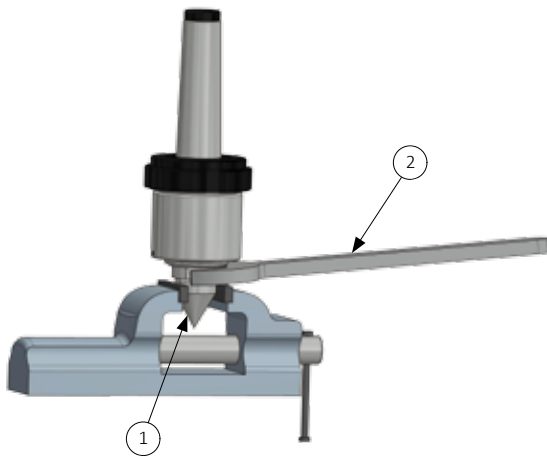

Per evitare il danneggiamento delle sedi cuscinetto dell'albero, estrarre la cuspide nel seguente modo:

- Bloccare in morsa la cuspide (1).
- Ruotare l'albero agendo con la chiave (2).

To avoid damage to the bearings seats of the shaft, extract the interchangeable center in the following way:

- *Lock the interchangeable center (1) in the vise.*
- *Act with the spanner (2) by rotating the shaft.*

REGISTRAZIONE DELLE CONTROPUNTE SERIE 80 ADJUSTING THE 80 SERIES LIVE CENTERS

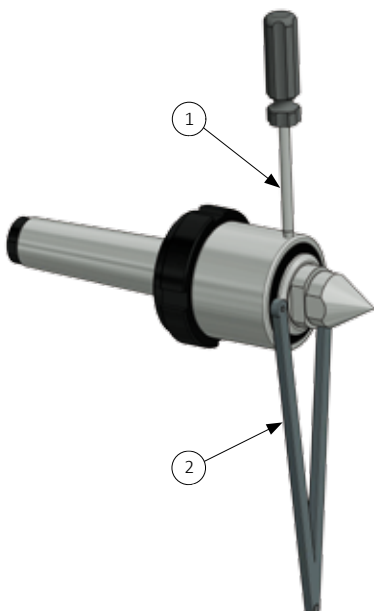

Per garantire il funzionamento ottimale ed esente da vibrazioni, occorrerà registrare la contropunta di tanto in tanto stringendo la ghiera fino a consentire all'anello del cuscinetto a rulli conici di essere sempre aderente ai rulli.

Per registrare la contropunta utilizzare il seguente metodo:

- Allentare la vite ferma-ghiera con un cacciavite (1).
- Allentare o stringere la ghiera di registrazione della contropunta tramite la chiave a compasso (2).

NOTA: Le contropunte serie 85 non necessitano di regolazione.

Le contropunte a carico differenziato diventano meno scorrevoli quando non sono in appoggio sul pezzo da tornire: questo è dovuto alla contropressione della molla che serve per differenziare il carico assiale sui reggispinta e non è un difetto costruttivo.

To ensure setting accuracy and avoid vibrations the live centers must occasionally be adjusted by tightening the nut until the cylindrical roller bearing ring is positioned firmly on the tapers.

To adjust the live center, use the following method:

- Loosen the locking nut screw with a screwdriver (1).*
- Loosen or tighten the live center adjusting nut with a pin spanner wrench (2)*

NOTE: The 85 series live centers need no adjustment.

As this is a live center with axial load distribution, when is not against the workpiece (therefore it's not subjected to axial load) it does not travel smoothly; this is due to the counter-pressure of the spring which distributes the axial load between the thrust bearings.

CONTROPUNTE SPECIALI

SPECIAL PRECISION LIVE CENTERS

CONTROPUNTA PER RULLATURA; HA UNA ROTAZIONE MOLTO FLUIDA GRAZIE AI SUOI 3 CUSCINETTI STUDIATI APPPOSITAMENTE PER QUESTA LAVORAZIONE.

LIVE CENTER FOR ROLLING; IT HAS A VERY SMOOTH ROTATION THANKS TO ITS 3 BEARINGS DESIGNED SPECIFICALLY FOR THIS PROCESS.

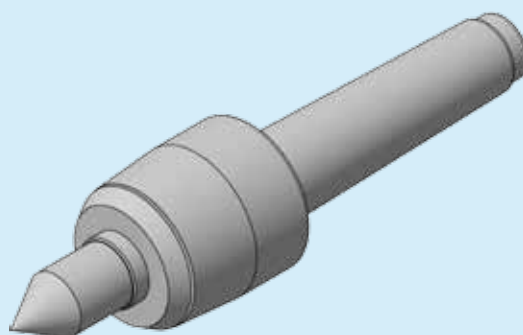

CONTROPUNTA ROTANTE SERIE 2000 CM5 SPECIALE E PUNTA FISSA CM5 PROLUNGATA SPECIALE; UTILI SU MACCHINE UTENSILI CON GRUPPO CONTROPUNTA ELETTRICO E LUNETTA.

SPECIAL LIVE CENTER 2000 SERIES MT5 AND SPECIAL EXTENDED DEAD CENTER MT5; USEFUL ON MACHINE TOOLS WITH ELECTRIC TAILSTOCK AND STEADY REST.

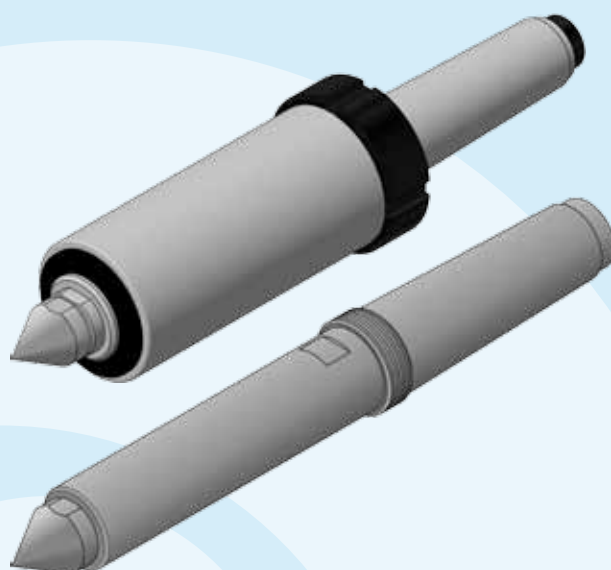

CONTROPUNTA ROTANTE PER STRUMENTI DI MISURA; HA UNA ROTAZIONE MOLTO SCORREVOLE E UNA CONCENTRICITÀ ENTRO 2 MICRON.

LIVE CENTER FOR MEASURING INSTRUMENTS; IT HAS A VERY SMOOTH ROTATION AND A CONCENTRICITY WITHIN 2 MICRONS.

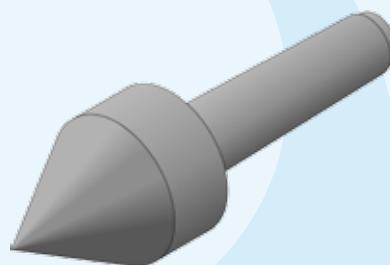

TECNOLOGIE FRB



FRB crea CONTROPUNTE SPECIALI progettate su specifiche del cliente!
FRB creates SPECIAL LIVE CENTERS specifically designed for the customer!



TECNOLOGIE **FRB** S.r.l.

ATTREZZATURE PER MACCHINE UTENSILI
EQUIPMENT FOR TOOL MACHINES

Lasciatevi “trascinare” nel mondo di Tecnologie FRB. Siamo presenti in più di 23 Paesi con una rete capillare di rivenditori e distributori e presenti nelle più importanti Fiere Internazionali.

Let yourself be “driven” into the FRB Technologies world. We are present in more than 23 Countries with a full network of retailers and distributors and at all the major Exhibitions world-wide.



+39 051 846760



info@tecnologiefrb.com



+39 051845306



www.tecnologiefrb.com



Via Cá Belfiore, 16
40037 Borgonuovo di Sasso Marconi (BO) Italy



CERTIFICAZIONE
SISTEMI DI GESTIONE
MANAGEMENT SYSTEMS
CERTIFICATION
ISO 9001:2008
nr. 50 100 10556

Rivenditore Autorizzato / Authorized Dealer

